



An Oshkosh Corporation Company

Operation and Safety Manual

Original Instructions - Keep this manual with the machine at all times.

Boom Lift Models

450A

450AJ

S/N 0300201991,

S/N 1300007279,

S/N E300002833,

& S/N B300003516

to Present

ANSI **CE**  **AS/NZS**

3121658

December 14, 2018 - Rev K



WARNING

Operating, servicing and maintaining this vehicle or equipment can expose you to chemicals including engine exhaust, carbon monoxide, phthalates, and lead, which are known to the State of California to cause cancer and birth defects or other reproductive harm. To minimize exposure, avoid breathing exhaust, do not idle the engine except as necessary, service your vehicle or equipment in a well-ventilated area and wear gloves or wash your hands frequently when servicing. For more information go to www.P65Warnings.ca.gov.

FOREWORD

This manual is a very important tool! Keep it with the machine at all times.

The purpose of this manual is to provide owners, users, operators, lessors, and lessees with the precautions and operating procedures essential for the safe and proper machine operation for its intended purpose.

Due to continuous product improvements, JLG Industries, Inc. reserves the right to make specification changes without prior notification. Contact JLG Industries, Inc. for updated information.

SAFETY ALERT SYMBOLS AND SAFETY SIGNAL WORDS



This is the Safety Alert Symbol. It is used to alert you to the potential personal injury hazards. Obey all safety messages that follow this symbol to avoid possible injury or death

⚠ DANGER

INDICATES AN IMMINENTLY HAZARDOUS SITUATION. IF NOT AVOIDED, WILL RESULT IN SERIOUS INJURY OR DEATH. THIS DECAL WILL HAVE A RED BACKGROUND.

⚠ WARNING

INDICATES A POTENTIALLY HAZARDOUS SITUATION. IF NOT AVOIDED, COULD RESULT IN SERIOUS INJURY OR DEATH. THIS DECAL WILL HAVE AN ORANGE BACKGROUND.

⚠ CAUTION

INDICATES A POTENTIALLY HAZARDOUS SITUATION. IF NOT AVOIDED, MAY RESULT IN MINOR OR MODERATE INJURY. IT MAY ALSO ALERT AGAINST UNSAFE PRACTICES. THIS DECAL WILL HAVE A YELLOW BACKGROUND.

NOTICE

INDICATES INFORMATION OR A COMPANY POLICY THAT RELATES DIRECTLY OR INDIRECTLY TO THE SAFETY OF PERSONNEL OR PROTECTION OF PROPERTY.

⚠ WARNING

THIS PRODUCT MUST COMPLY WITH ALL SAFETY RELATED BULLETINS. CONTACT JLG INDUSTRIES, INC. OR THE LOCAL AUTHORIZED JLG REPRESENTATIVE FOR INFORMATION REGARDING SAFETY-RELATED BULLETINS WHICH MAY HAVE BEEN ISSUED FOR THIS PRODUCT.

NOTICE

JLG INDUSTRIES, INC. SENDS SAFETY RELATED BULLETINS TO THE OWNER OF RECORD OF THIS MACHINE. CONTACT JLG INDUSTRIES, INC. TO ENSURE THAT THE CURRENT OWNER RECORDS ARE UPDATED AND ACCURATE.

NOTICE

JLG INDUSTRIES, INC. MUST BE NOTIFIED IMMEDIATELY IN ALL INSTANCES WHERE JLG PRODUCTS HAVE BEEN INVOLVED IN AN ACCIDENT INVOLVING BODILY INJURY OR DEATH OF PERSONNEL OR WHEN SUBSTANTIAL DAMAGE HAS OCCURRED TO PERSONAL PROPERTY OR THE JLG PRODUCT.

For:

- Accident Reporting
- Product Safety Publications
- Current Owner Updates
- Questions Regarding Product Safety
- Standards and Regulations Compliance Information
- Questions Regarding Special Product Applications
- Questions Regarding Product Modifications

Contact:

Product Safety and Reliability Department
JLG Industries, Inc.
13224 Fountainhead Plaza
Hagerstown, MD 21742
USA

or Your Local JLG Office
(See addresses on rear cover)

In USA:

Toll Free: 877-JLG-SAFE (877-554-7233)

Outside USA:

Phone: 240-420-2661
Fax: 301-745-3713
E-mail: ProductSafety@JLG.com

REVISION LOG

Original Issue	A - February 2, 2015
Revised	B - April 2, 2015
Revised	C - July 6, 2015
Revised	D- January 19, 2016
Revised	E - July 19, 2016
Revised	F - January 23, 2017
Revised	G - June 30, 2017
Revised	H - September 20, 2017
Revised	I - June 29, 2018 - Revised Covers, Prop 65
Revised	J - November 5, 2018
Revised	K - December 14, 2018

SECTION - PARAGRAPH, SUBJECT	PAGE
SECTION - 1 - SAFETY PRECAUTIONS	
1.1 GENERAL	1-1
1.2 PRE-OPERATION	1-1
Operator Training and Knowledge	1-1
Workplace Inspection	1-2
Machine Inspection	1-3
1.3 OPERATION	1-3
General	1-3
Trip and Fall Hazards	1-4
Electrocution Hazards	1-5
Tipping Hazards	1-7
Crushing and Collision Hazards	1-10
1.4 TOWING, LIFTING, AND HAULING	1-11
1.5 MAINTENANCE	1-11
Maintenance Hazards	1-11
Battery Hazards	1-13
SECTION - 2 - USER RESPONSIBILITIES, MACHINE PREPARATION, AND INSPECTION	
2.1 PERSONNEL TRAINING	2-1
Operator Training	2-1
Training Supervision	2-1
Operator Responsibility	2-1
2.2 PREPARATION, INSPECTION, AND MAINTENANCE	2-2
Pre-Start Inspection	2-5
Function Check	2-8

SECTION - PARAGRAPH, SUBJECT	PAGE
SkyGuard Function Test	2-9
2.3 OSCILLATING AXLE LOCKOUT TEST	2-10
SECTION - 3 - MACHINE CONTROLS AND INDICATORS	
3.1 GENERAL	3-1
3.2 CONTROLS AND INDICATORS	3-1
Ground Control Console	3-2
Ground Control Indicator Panel	3-8
Ground Control Console Display Gauge	3-12
Platform Console	3-15
Platform Control Indicator Panel	3-20
SECTION - 4 - MACHINE OPERATION	
4.1 DESCRIPTION	4-1
4.2 BOOM OPERATING CHARACTERISTICS AND LIMITATIONS	4-2
Capacities	4-2
Stability	4-2
4.3 ENGINE OPERATION	4-3
Starting Procedure	4-3
Shutdown Procedure	4-4
Fuel Reserve / Shut-Off System	4-5
4.4 TRAVELING (DRIVING)	4-7
Traveling Forward and Reverse	4-9
Traveling on a Grade	4-10

TABLE OF CONTENTS

SECTION - PARAGRAPH, SUBJECT	PAGE	SECTION - PARAGRAPH, SUBJECT	PAGE
4.5 STEERING.....	4-10	SECTION - 5 - EMERGENCY PROCEDURES	
4.6 PLATFORM	4-10	5.1 GENERAL	5-1
Platform Level Adjustment	4-10	5.2 INCIDENT NOTIFICATION.....	5-1
Platform Rotation	4-10	5.3 EMERGENCY OPERATION	5-1
4.7 BOOM.....	4-11	Operator Unable to Control Machine.....	5-1
Swinging the Boom	4-11	Platform or Boom Caught Overhead	5-2
Raising and Lowering the Tower Boom.....	4-11	5.4 MANUAL SWING OVERRIDE	5-2
Raising and Lowering the Main Boom.....	4-12	5.5 EMERGENCY TOWING PROCEDURES.....	5-3
Telescoping the Main Boom	4-12	5.6 MACHINE SAFETY SYSTEM OVERRIDE (MSSO)	
4.8 FUNCTION SPEED CONTROL	4-12	(CE ONLY)	5-4
4.9 MACHINE SAFETY SYSTEM OVERRIDE (MSSO)			
(CE ONLY)	4-12	SECTION - 6 - ACCESSORIES	
4.10 SKYGUARD OPERATION	4-13	6.1 FALL ARREST PLATFORM.....	6-3
SkyGuard	4-13	Safety Precautions.....	6-3
SkyGuard - SkyLine	4-13	6.2 PIPE RACKS	6-3
SkyGuard - SkyEye.....	4-14	Capacity Specifications (Australia Only)	6-4
SkyGuard Function Table	4-14	Safety Precautions.....	6-4
4.11 SHUT DOWN AND PARK.....	4-15	Preparation and Inspection	6-4
Shut Down and Park.....	4-15	Operation.....	6-4
4.12 LIFTING AND TIE DOWN.....	4-15	6.3 SKYGLAZIER™.....	6-5
Lifting.....	4-15	Capacity Specifications	6-5
Tie Down.....	4-15	Safety Precautions.....	6-6
		Preparation and Inspection.....	6-6
		Operation.....	6-6

SECTION - PARAGRAPH, SUBJECT	PAGE
6.4 SKYPOWER™	6-7
Generator Output	6-7
Accessory Ratings	6-7
Safety Precautions	6-8
Preparation and Inspection	6-8
Operation	6-8
6.5 SKYWELDER™	6-8
Accessory Ratings	6-9
Generator Output	6-9
Welding Accessories	6-9
Safety Precautions	6-10
Preparation and Inspection	6-10
Operation	6-10
6.6 SOFT TOUCH	6-11

SECTION - 7 - GENERAL SPECIFICATIONS & OPERATOR MAINTENANCE

7.1 INTRODUCTION	7-1
7.2 OPERATING SPECIFICATIONS AND PERFORMANCE DATA	7-1
Operating Specifications	7-1
Dimensional Data	7-2
Capacities	7-2
Tires	7-3
Engine Data	7-3
Hydraulic Oil	7-5

SECTION - PARAGRAPH, SUBJECT	PAGE
Major Component Weights	7-8
7.3 OPERATOR MAINTENANCE	7-21
7.4 TIRES & WHEELS	7-35
Tire Replacement	7-35
Wheel and Tire Replacement	7-35
Wheel Installation	7-35
7.5 PROPANE FUEL FILTER REPLACEMENT (GM ENGINE) ..	7-37
Removal	7-37
Installation	7-38
7.6 PROPANE FUEL FILTER REPLACEMENT (KUBOTA ENGINE)	7-38
Removal	7-38
Installation	7-39
7.7 PROPANE FUEL SYSTEM PRESSURE RELIEF	7-40
7.8 SUPPLEMENTAL INFORMATION	7-40

SECTION - 8 - INSPECTION AND REPAIR LOG

TABLE OF CONTENTS

SECTION - PARAGRAPH, SUBJECT	PAGE	SECTION - PARAGRAPH, SUBJECT	PAGE
-------------------------------------	-------------	-------------------------------------	-------------

This Page Left Blank Intentionally

FIGURE NUMBER - TITLE	PAGE	FIGURE NUMBER - TITLE	PAGE
2-1. Basic Nomenclature.....	2-4	7-3. Engine Operating Temperature Specifications - GM - Sheet 1 of 27-11	
3-1. Ground Control Console	3-3	7-4. Engine Operating Temperature Specifications - GM - Sheet 2 of 27-12	
3-2. Ground Control Console with MSSO (CE Only)	3-4	7-5. Engine Operating Temperature Specifications - Deutz 2.9L	7-13
3-3. Ground Control Indicator Panel	3-9	7-6. Hydraulic Oil Operation Chart - Sheet 1 of 2.....	7-14
3-4. Ground Control Indicator Panel - Kubota Engine	3-10	7-7. Hydraulic Oil Operation Chart - Sheet 2 of 2.....	7-15
3-5. Splash Screen.....	3-12	7-8. Engine Oil Operation Chart - Kubota.....	7-16
3-6. Diagnostic Screen.....	3-13	7-9. Operator Maintenance and Lubrication Diagram - Deutz 2.3L Engine7-17	
3-7. Engine Diagnostic Screen	3-13	7-10. Operator Maintenance and Lubrication Diagram - GM ... Engine7-18	
3-8. Ground Control Console Display Gauge	3-14	7-11. Operator Maintenance and Lubrication Diagram - Deutz 2.9L Engine7-19	
3-9. Platform Control Console	3-16	7-12. Operator Maintenance and Lubrication Diagram - Kubota Engine7-20	
3-10. Platform Control Indicator Panel.....	3-21	7-13. GM Filter Lock Assembly	7-37
4-1. Position of Least Forward Stability.....	4-6	7-14. Kubota Filter Lock Assembly	7-39
4-2. Position of Least Backward Stability	4-7		
4-3. Grade and Side Slopes	4-8		
4-4. Traveling on a Grade.....	4-10		
4-5. Lifting and Tie Down Chart	4-16		
4-6. Decal Location Sheet 1 of 6.....	4-17		
4-7. Decal Location Sheet 2 of 6.....	4-18		
4-8. Decal Location Sheet 3 of 6.....	4-19		
4-9. Decal Location Sheet 4 of 6.....	4-20		
4-10. Decal Location Sheet 5 of 6.....	4-21		
4-11. Decal Location Sheet 6 of 6.....	4-22		
7-1. Engine Operating Temperature Specifications - Deutz 2.3L - Sheet 1 of 27-9			
7-2. Engine Operating Temperature Specifications - Deutz 2.3L - Sheet 2 of 27-10			

LIST OF FIGURES

FIGURE NUMBER - TITLE

PAGE

FIGURE NUMBER - TITLE

PAGE

This Page Left Blank Intentionally

TABLE NUMBER - TITLE	PAGE	TABLE NUMBER - TITLE	PAGE
1-1	Minimum Approach Distances (M.A.D.)	1-6	
1-2	Beaufort Scale (For Reference Only).....	1-9	
2-1	Inspection and Maintenance Table	2-3	
4-1	Decal Legend - Language Markets	4-23	
4-2	Decal Legend - Kubota Engine-Powered Machines ...	4-26	
6-1	Available Accessories	6-1	
6-2	Options/Accessories Relationship Table.....	6-2	
7-1	Operating Specifications	7-1	
7-2	Dimensional Data	7-2	
7-3	Capacities	7-2	
7-4	Tires	7-3	
7-5	Deutz D2011L03	7-3	
7-6	Deutz D2.9L4	7-4	
7-7	GM 3.0L	7-4	
7-8	Kubota WG 2503	7-5	
7-9	Hydraulic Oil	7-5	
7-10	Mobilfluid 424 Specs	7-6	
7-11	DTE 10 Excel 15 Specs	7-6	
7-12	Quintolubric 888-46.....	7-7	
7-13	Mobil EAL 224H Specs	7-7	
7-14	Exxon Univis HVI 26 Specs	7-8	
7-15	Critical Stability Weights.....	7-8	
7-16	Lubrication Specifications.....	7-21	
7-17	Wheel Torque Chart.....	7-36	
8-1	Inspection and Repair Log.....	8-1	

LIST OF TABLES

TABLE NUMBER - TITLE

PAGE

TABLE NUMBER - TITLE

PAGE

This Page Left Blank Intentionally

SECTION 1. SAFETY PRECAUTIONS

1.1 GENERAL

This section outlines the necessary precautions for proper and safe machine usage and maintenance. It is mandatory that a daily routine is established based on the content of this manual to promote proper machine usage. A maintenance program, using the information provided in this manual and the Service and Maintenance Manual, must also be established by a qualified person and must be followed to ensure that the machine is safe to operate.

The owner/user/operator/lessor/lessee of the machine must not accept operating responsibility until this manual has been read, training is accomplished, and operation of the machine has been completed under the supervision of an experienced and qualified operator.

This section contains the responsibilities of the owner, user, operator, lessor, and lessee concerning safety, training, inspection, maintenance, application, and operation. If there are any questions with regard to safety, training, inspection, maintenance, application, and operation, please contact JLG Industries, Inc. ("JLG").

WARNING

FAILURE TO COMPLY WITH THE SAFETY PRECAUTIONS LISTED IN THIS MANUAL COULD RESULT IN MACHINE DAMAGE, PROPERTY DAMAGE, PERSONAL INJURY OR DEATH.

1.2 PRE-OPERATION

Operator Training and Knowledge

- The Operation and Safety Manual must be read and understood in its entirety before operating the machine. For clarification, questions, or additional information regarding any portions of this manual, contact JLG Industries, Inc.

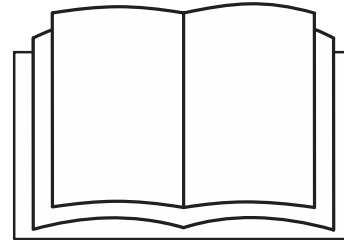

SECTION 1 - SAFETY PRECAUTIONS

- An operator must not accept operating responsibilities until adequate training has been given by competent and authorized persons.
- Allow only those authorized and qualified personnel to operate the machine who have demonstrated that they understand the safe and proper operation and maintenance of the unit.
- Read, understand, and obey all DANGERS, WARNINGS, CAUTIONS, and operating instructions on the machine and in this manual.
- Ensure that the machine is to be used in a manner which is within the scope of its intended application as determined by JLG.
- All operating personnel must be familiar with the emergency controls and emergency operation of the machine as specified in this manual.
- Read, understand, and obey all applicable employer, local, and governmental regulations as they pertain to your utilization and application of the machine.

Workplace Inspection

- Precautions to avoid all hazards in the work area must be taken by the user before and during operation of the machine.
- Do not operate or raise the platform from a position on trucks, trailers, railway cars, floating vessels, scaffolds or other equipment unless the application is approved in writing by JLG.
- Before operation, check work area for overhead hazards such as electric lines, bridge cranes, and other potential overhead obstructions.
- Check operating surfaces for holes, bumps, drop-offs, obstructions, debris, concealed holes, and other potential hazards.
- Check the work area for hazardous locations. Do not operate the machine in hazardous environments unless approved for that purpose by JLG.
- Ensure that the ground conditions are adequate to support the maximum tire load indicated on the tire load decals located on the chassis adjacent to each wheel. Do not travel on unsupported surfaces.

Machine Inspection

- Do not operate this machine until the inspections and functional checks as specified in Section 2 of this manual have been performed.
- Do not operate this machine until it has been serviced and maintained according to the maintenance and inspection requirements as specified in the machine's Service and Maintenance Manual.
- Ensure all safety devices are operating properly. Modification of these devices is a safety violation.

WARNING

MODIFICATION OR ALTERATION OF AN AERIAL WORK PLATFORM SHALL BE MADE ONLY WITH PRIOR WRITTEN PERMISSION FROM THE MANUFACTURER.

- Do not operate any machine on which the safety or instruction placards or decals are missing or illegible.
- Check the machine for modifications to original components. Ensure that any modifications have been approved by JLG.
- Avoid accumulation of debris on platform floor. Keep mud, oil, grease, and other slippery substances from footwear and platform floor.

1.3 OPERATION

General

- Machine operation requires your full attention. Bring the machine to a full stop before using any device, i.e. cell phones, two-way radios, etc. that will distract your attention from safely operating the machine.
- Do not use the machine for any purpose other than positioning personnel, their tools, and equipment.
- Before operation, the user must be familiar with the machine capabilities and operating characteristics of all functions.
- Never operate a malfunctioning machine. If a malfunction occurs, shut down the machine. Remove the unit from service and notify the proper authorities.
- Do not remove, modify, or disable any safety devices.
- Never slam a control switch or lever through neutral to an opposite direction. Always return switch to neutral and stop before moving the switch to the next function. Operate controls with slow and even pressure.
- Do not allow personnel to tamper with or operate the machine from the ground with personnel in the platform, except in an emergency.

SECTION 1 - SAFETY PRECAUTIONS

- Do not carry materials directly on platform railing unless approved by JLG.
- When two or more persons are in the platform, the operator shall be responsible for all machine operations.
- Always ensure that power tools are properly stowed and never left hanging by their cord from the platform work area.
- When driving, always position boom over rear axle in line with the direction of travel. Remember, if boom is over the front axle, steer and drive functions will be reversed.
- Do not assist a stuck or disabled machine by pushing or pulling except by pulling at the chassis tie-down lugs.
- Fully lower platform and shut off all power before leaving machine.
- Remove all rings, watches, and jewelry when operating machine. Do not wear loose fitting clothing or long hair unrestrained which may become caught or entangled in equipment.
- Persons under the influence of drugs or alcohol or who are subject to seizures, dizziness or loss of physical control must not operate this machine.

- Hydraulic cylinders are subject to thermal expansion and contraction. This may result in changes to the boom and/or platform position while the machine is stationary. Factors affecting thermal movement can include the length of time the machine will remain stationary, hydraulic oil temperature, ambient air temperature, and boom and platform position.

Trip and Fall Hazards

- During operation, occupants in the platform must wear a full body harness with a lanyard attached to an authorized lanyard anchorage point. Attach only one (1) lanyard per lanyard anchorage point.

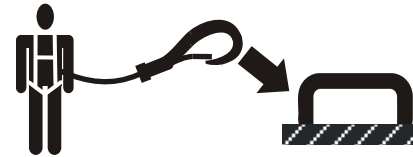

- Enter and exit only through gate area. Use extreme caution when entering or leaving platform. Ensure that the platform assembly is fully lowered. Face the machine when entering or leaving the platform. Always maintain “three point contact” with the machine, using two hands and one foot or two feet and one hand at all times during entry and exit.

- Before operating the machine, make sure all gates are closed and fastened in their proper position.

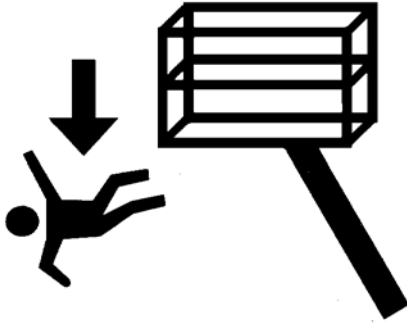

- Keep both feet firmly positioned on the platform floor at all times. Never position ladders, boxes, steps, planks, or similar items on unit to provide additional reach for any purpose.
- Keep oil, mud, and slippery substances cleaned from footwear and the platform floor.

Electrocution Hazards

- This machine is not insulated and does not provide protection from contact or proximity to electrical current.

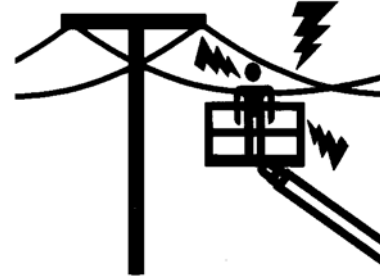

SECTION 1 - SAFETY PRECAUTIONS

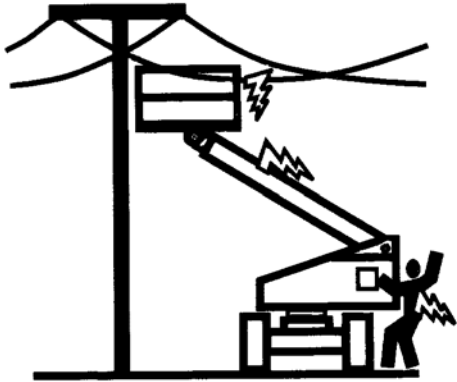

- Maintain distance from electrical lines, apparatus, or any energized (exposed or insulated) parts according to the Minimum Approach Distance (MAD) as shown in Table 1-1.
- Allow for machine movement and electrical line swaying.

Table 1-1. Minimum Approach Distances (M.A.D.)

Voltage Range (Phase to Phase)	MINIMUM APPROACH DISTANCE in Feet (Meters)
0 to 50 KV	10 (3)
Over 50KV to 200 KV	15 (5)
Over 200 KV to 350 KV	20 (6)
Over 350 KV to 500 KV	25 (8)
Over 500 KV to 750 KV	35 (11)
Over 750 KV to 1000 KV	45 (14)

NOTE: *This requirement shall apply except where employer, local or governmental regulations are more stringent.*

- Maintain a clearance of at least 10 ft. (3m) between any part of the machine and its occupants, their tools, and their equipment from any electrical line or apparatus carrying up to 50,000 volts. One foot additional clearance is required for every additional 30,000 volts or less.

- The minimum approach distance may be reduced if insulating barriers are installed to prevent contact, and the barriers are rated for the voltage of the line being guarded. These barriers shall not be part of (or attached to) the machine. The minimum approach distance shall be reduced to a distance within the designed working dimensions of the insulating barrier. This determination shall be made by a qualified person in accordance with the employer, local, or governmental requirements for work practices near energized equipment.

⚠ DANGER

DO NOT MANEUVER MACHINE OR PERSONNEL INSIDE PROHIBITED ZONE (MAD). ASSUME ALL ELECTRICAL PARTS AND WIRING ARE ENERGIZED UNLESS KNOWN OTHERWISE.

Tipping Hazards

- The user must be familiar with the surface before driving. Do not exceed the allowable sideslope and grade while driving.

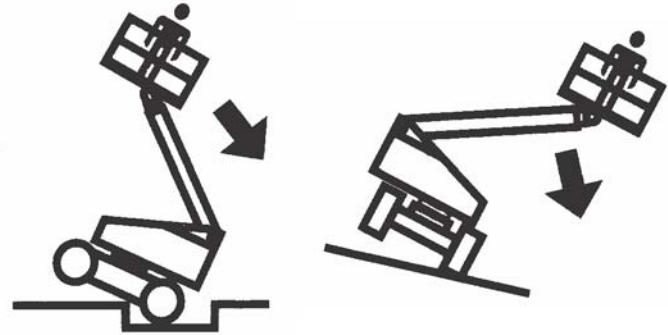

- Do not elevate platform or drive with platform elevated while on or near a sloping, uneven, or soft surface. Ensure machine is positioned on a firm, level and smooth surface before elevating platform or driving with the platform in the elevated position.
- Before driving on floors, bridges, trucks, and other surfaces, check allowable capacity of the surfaces.

SECTION 1 - SAFETY PRECAUTIONS

- Never exceed the maximum work load as specified on the platform. Keep all loads within the confines of the platform, unless authorized by JLG.
- Keep the chassis of the machine a minimum of 2 ft. (0.6m) from holes, bumps, drop-offs, obstructions, debris, concealed holes, and other potential hazards at the ground level.
- Do not push or pull any object with the boom.
- Never attempt to use the machine as a crane. Do not tie-off machine to any adjacent structure. Never attach wire, cable, or any similar items to platform.
- If boom assembly or platform is in a position that one or more wheels are off the ground, all persons must be removed before attempting to stabilize the machine. Use cranes, forklift trucks, or other appropriate equipment to stabilize machine.
- Do not operate the machine when wind conditions, including gusts, may exceed 28 mph (12.5 m/s). Factors affecting wind speed are; platform elevation, surrounding structures, local weather events, and approaching storms. Refer to Table 1-2, Beaufort scale (For Reference Only) or use other means to monitor wind conditions.
- Wind speed can be significantly greater at height than at ground level.
- Wind speed can change rapidly. Always consider approaching weather events, the time required to lower the platform, and methods to monitor current and potential wind conditions.
- Do not increase surface area of the platform or the load. Increased areas exposed to wind will decrease stability.
- Do not increase the platform size with unauthorized modifications or attachments.

NOTICE

DO NOT OPERATE THE MACHINE WHEN WIND CONDITIONS EXCEED 28 MPH (12.5 M/S).

Table 1-2. Beaufort Scale (For Reference Only)

Beaufort Number	Wind Speed		Description	Land Conditions
	mph	m/s		
0	0	0-0.2	Calm	Calm. Smoke rises vertically
1	1-3	0.3-1.5	Light air	Wind motion visible in smoke
2	4-7	1.6-3.3	Light breeze	Wind felt on exposed skin. Leaves rustle
3	8-12	3.4-5.4	Gentle breeze	Leaves and smaller twigs in constant motion
4	13-18	5.5-7.9	Moderate breeze	Dust and loose paper raised. Small branches begin to move.
5	19-24	8.0-10.7	Fresh breeze	Smaller trees sway.
6	25-31	10.8-13.8	Strong breeze	Large branches in motion. Flags waving near horizontal. Umbrella use becomes difficult.
7	32-38	13.9-17.1	Near Gale/Moderate Gale	Whole trees in motion. Effort needed to walk against the wind.
8	39-46	17.2-20.7	Fresh Gale	Twigs broken from trees. Cars veer on road.
9	47-54	20.8-24.4	Strong Gale	Light structure damage.

Crushing and Collision Hazards

- Approved head gear must be worn by all operating and ground personnel.
- Check work area for clearances overhead, on sides, and bottom of platform when lifting or lowering platform, and driving.

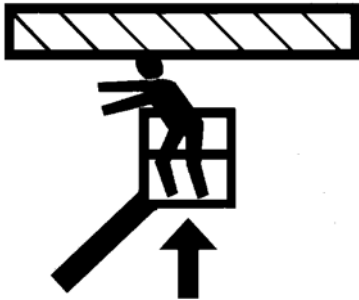

- During operation, keep all body parts inside platform railing.
- Use the boom functions, not the drive function, to position the platform close to obstacles.
- Always post a lookout when driving in areas where vision is obstructed.

- Keep non-operating personnel at least 6 ft. (1.8m) away from machine during all driving and swing operations.
- Under all travel conditions, the operator must limit travel speed according to conditions of ground surface, congestion, visibility, slope, location of personnel, and other factors which may cause collision or injury to personnel.
- Be aware of stopping distances in all drive speeds. When driving in high speed, switch to low speed before stopping. Travel grades in low speed only.
- Do not use high speed drive in restricted or close quarters or when driving in reverse.
- Exercise extreme caution at all times to prevent obstacles from striking or interfering with operating controls and persons in the platform.
- Be sure that operators of other overhead and floor level machines are aware of the aerial work platform's presence. Disconnect power to overhead cranes.
- Warn personnel not to work, stand, or walk under a raised boom or platform. Position barricades on floor if necessary.

1.4 TOWING, LIFTING, AND HAULING

- Never allow personnel in platform while towing, lifting, or hauling.
- This machine should not be towed, except in the event of emergency, malfunction, power failure, or loading/unloading. Refer to the Emergency Procedures section of this manual for emergency towing procedures.
- Ensure boom is in the stowed position and, if equipped, the turntable locked prior to towing, lifting or hauling. The platform must be completely empty of tools.
- When lifting machine, lift only at designated areas of the machine. Lift the unit with equipment of adequate capacity.
- Refer to the Machine Operation section of this manual for lifting information.

1.5 MAINTENANCE

This sub-section contains general safety precautions which must be observed during maintenance of this machine. Additional precautions to be observed during machine maintenance are inserted at the appropriate points in this manual and in the Service and Maintenance Manual. It is of utmost importance that maintenance personnel pay strict attention to these precautions to avoid possible injury to personnel or damage to the machine or property. A maintenance program must be established by a qualified person and must be followed to ensure that the machine is safe.

Maintenance Hazards

- Shut off power to all controls and ensure that all moving parts are secured from inadvertent motion prior to performing any adjustments or repairs.
- Never work under an elevated platform until it has been fully lowered to the full down position, if possible, or otherwise supported and restrained from movement with appropriate safety props, blocking, or overhead supports.
- DO NOT attempt to repair or tighten any hydraulic hoses or fittings while the machine is powered on or when the hydraulic system is under pressure.
- Always relieve hydraulic pressure from all hydraulic circuits before loosening or removing hydraulic components.

SECTION 1 - SAFETY PRECAUTIONS

- DO NOT use your hand to check for leaks. Use a piece of cardboard or paper to search for leaks. Wear gloves to help protect hands from spraying fluid.



- Ensure replacement parts or components are identical or equivalent to original parts or components.
- Never attempt to move heavy parts without the aid of a mechanical device. Do not allow heavy objects to rest in an unstable position. Ensure adequate support is provided when raising components of the machine.

- Do not use machine as a ground for welding.
- When performing welding or metal cutting operations, precautions must be taken to protect the chassis from direct exposure to weld and metal cutting spatter.
- Do not refuel the machine with the engine running.
- Use only approved non-flammable cleaning solvents.
- Do not replace items critical to stability, such as batteries or solid tires, with items of different weight or specification. Do not modify unit in any way to affect stability.
- Refer to the Service and Maintenance Manual for the weights of critical stability items.

⚠ WARNING

MODIFICATION OR ALTERATION OF AN AERIAL WORK PLATFORM SHALL BE MADE ONLY WITH PRIOR WRITTEN PERMISSION FROM THE MANUFACTURER.

Battery Hazards

- Always disconnect batteries when servicing electrical components or when performing welding on the machine.
- Do not allow smoking, open flame, or sparks near battery during charging or servicing.
- Do not contact tools or other metal objects across the battery terminals.
- Always wear hand, eye, and face protection when servicing batteries. Ensure that battery acid does not come in contact with skin or clothing.

CAUTION

BATTERY FLUID IS HIGHLY CORROSIVE. AVOID CONTACT WITH SKIN AND CLOTHING AT ALL TIMES. IMMEDIATELY RINSE ANY CONTACTED AREA WITH CLEAN WATER AND SEEK MEDICAL ATTENTION.

- Charge batteries only in a well ventilated area.
- Avoid overfilling the battery fluid level. Add distilled water to batteries only after the batteries are fully charged.

SECTION 2. USER RESPONSIBILITIES, MACHINE PREPARATION, AND INSPECTION

2.1 PERSONNEL TRAINING

The aerial platform is a personnel handling device; so it is necessary that it be operated and maintained only by trained personnel.

Persons under the influence of drugs or alcohol or who are subject to seizures, dizziness or loss of physical control must not operate this machine.

Operator Training

Operator training must cover:

1. Use and limitations of the controls in the platform and at the ground, emergency controls and safety systems.
2. Control labels, instructions, and warnings on the machine.
3. Rules of the employer and government regulations.
4. Use of approved fall protection device.
5. Enough knowledge of the mechanical operation of the machine to recognize a malfunction or potential malfunction.

6. The safest means to operate the machine where overhead obstructions, other moving equipment, and obstacles, depressions, holes, or drop-offs exist.
7. Means to avoid the hazards of unprotected electrical conductors.
8. Specific job requirements or machine application.

Training Supervision

Training must be done under the supervision of a qualified person in an open area free of obstructions until the trainee has developed the ability to safely control and operate the machine.

Operator Responsibility

The operator must be instructed that he/she has the responsibility and authority to shut down the machine in case of a malfunction or other unsafe condition of either the machine or the job site.

2.2 PREPARATION, INSPECTION, AND MAINTENANCE

The following table covers the periodic machine inspections and maintenance required by JLG Industries, Inc. Consult local regulations for further requirements for aerial work platforms. The frequency of inspections and maintenance must be increased as necessary when the machine is used in a harsh or hostile environment, if the machine is used with increased frequency, or if the machine is used in a severe manner.

NOTICE

JLG INDUSTRIES, INC. RECOGNIZES A FACTORY TRAINED SERVICE TECHNICIAN AS A PERSON WHO HAS SUCCESSFULLY COMPLETED THE JLG SERVICE TRAINING SCHOOL FOR THE SPECIFIC JLG PRODUCT MODEL.

SECTION 2 - USER RESPONSIBILITIES, MACHINE PREPARATION, AND INSPECTION

Table 2-1. Inspection and Maintenance Table

Type	Frequency	Primary Responsibility	Service Qualification	Reference
Pre-Start Inspection	Before using each day; or whenever there's an Operator change.	User or Operator	User or Operator	Operator and Safety Manual
Pre-Delivery Inspection (See Note)	Before each sale, lease, or rental delivery.	Owner, Dealer, or User	Qualified JLG Mechanic	Service and Maintenance Manual and applicable JLG inspection form
Frequent Inspection (See Note)	In service for 3 months or 150 hours, whichever comes first; or Out of service for a period of more than 3 months; or Purchased used.	Owner, Dealer, or User	Qualified JLG Mechanic	Service and Maintenance Manual and applicable JLG inspection form
Annual Machine Inspection (See Note)	Annually, no later than 13 months from the date of prior inspection.	Owner, Dealer, or User	Factory Trained Service Technician (Recommended)	Service and Maintenance Manual and applicable JLG inspection form
Preventative Maintenance	At intervals as specified in the Service and Maintenance Manual.	Owner, Dealer, or User	Qualified JLG Mechanic	Service and Maintenance Manual
NOTE: Inspection forms are available from JLG. Use the Service and Maintenance Manual to perform inspections.				

SECTION 2 - USER RESPONSIBILITIES, MACHINE PREPARATION, AND INSPECTION

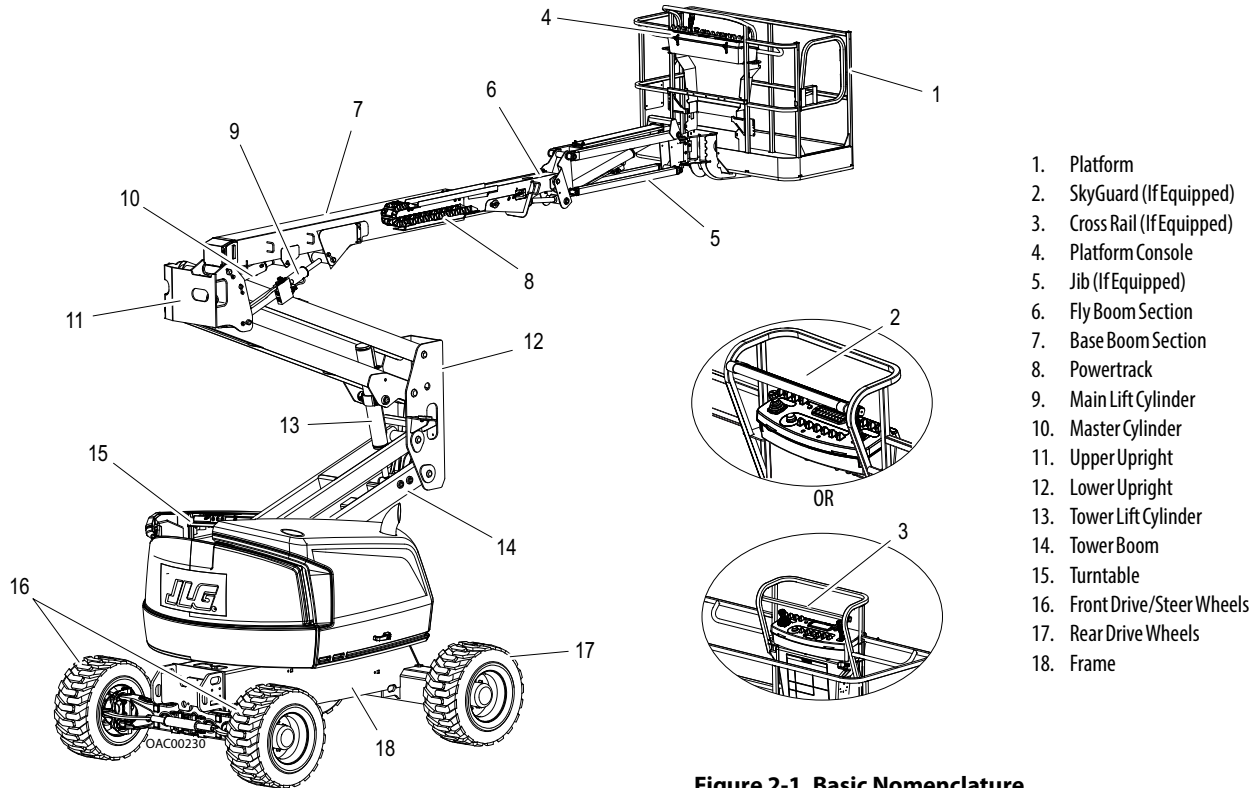
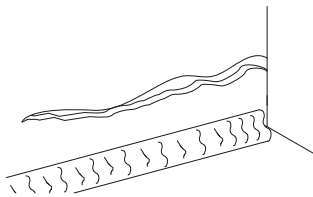

Figure 2-1. Basic Nomenclature

Pre-Start Inspection

The Pre-Start Inspection should include each of the following:

1. **Cleanliness** – Check all surfaces for leakage (oil, fuel, or battery fluid) or foreign objects. Report any leakage to the proper maintenance personnel.
2. **Structure** – Inspect the machine structure for dents, damage, weld or parent metal cracks or other discrepancies.



Parent Metal Crack

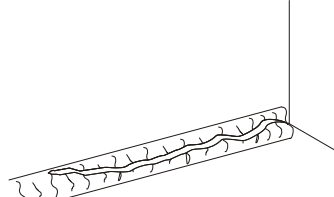

Weld Crack

3. **Decals and Placards** – Check all for cleanliness and legibility. Make sure none of the decals and placards are missing. Make sure all illegible decals and placards are cleaned or replaced.
4. **Operation and Safety Manuals** – Make sure a copy of the Operation and Safety Manual, AEM Safety Manual (ANSI markets only), and ANSI Manual of Responsibilities (ANSI markets only) is enclosed in the weather resistant storage container.

5. **Daily Walk-Around Inspection** – Perform as instructed.
6. **Battery** – Charge as required.
7. **Fuel** (Combustion Engine Powered Machines) – Add the proper fuel as necessary.
8. **Engine Oil Supply** – Ensure the engine oil level is at the Full mark on the dipstick and the filler cap is secure.
9. **Hydraulic Oil** – Check the hydraulic oil level. Ensure hydraulic oil is added as required.
10. **Accessories/Attachments** – Refer to the Accessories section in this manual or the accessory installed upon the machine for specific inspection, operation, and maintenance instructions.
11. **Function Check** – Once the “Walk-Around” Inspection is complete, perform a functional check of all systems in an area free of overhead and ground level obstructions. Refer to Section 4 for more specific operating instructions.

WARNING

IF THE MACHINE DOES NOT OPERATE PROPERLY, TURN OFF THE MACHINE IMMEDIATELY! REPORT THE PROBLEM TO THE PROPER MAINTENANCE PERSONNEL. DO NOT OPERATE THE MACHINE UNTIL IT IS DECLARED SAFE FOR OPERATION.

SECTION 2 - USER RESPONSIBILITIES, MACHINE PREPARATION, AND INSPECTION

Daily Walk-Around Inspection

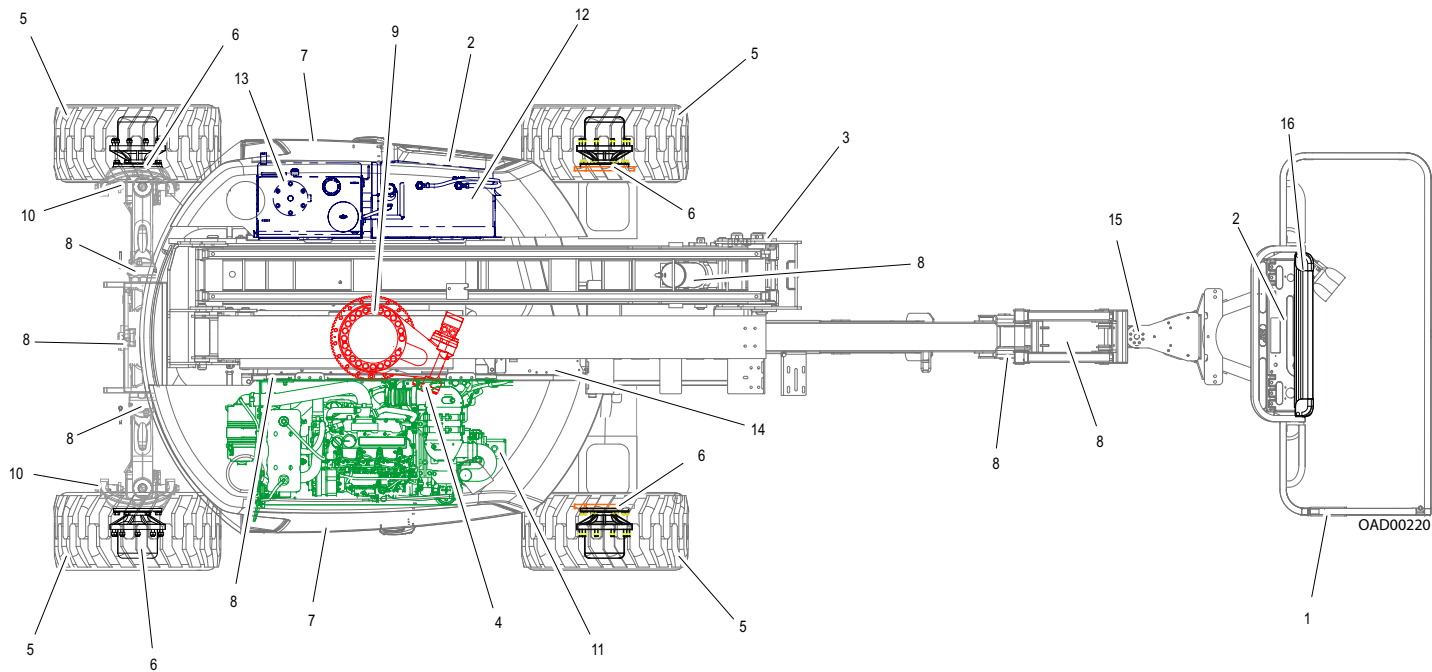

SECTION 2 - USER RESPONSIBILITIES, MACHINE PREPARATION, AND INSPECTION

Begin the "Walk-Around Inspection" at Item 1, as noted on the diagram. Continue checking each item in sequence for the conditions listed in the following checklist.

WARNING

TO AVOID POSSIBLE INJURY, BE SURE MACHINE POWER IS OFF.

DO NOT OPERATE MACHINE UNTIL ALL MALFUNCTIONS HAVE BEEN CORRECTED.

***INSPECTION NOTE:** On all components, make sure there are no loose or missing parts, that they are securely fastened, and no visible damage, leaks or excessive wear exists in addition to any other criteria mentioned.*

- 1. Platform Assembly and Gate** - Footswitch works properly, not modified, disabled or blocked. Latch and hinges in working condition.
- 2. Platform & Ground Control Consoles** - Switches and levers return to neutral, decals/placards secure and legible, control markings legible.
- 3. Boom Sections/Uprights/Turntable** - See Inspection Note.
- 4. Swing Motor and Worm Gear** - No evidence of damage.
- 5. Wheel/Tire Assemblies** - Properly secured, no missing lug nuts. Inspect for worn tread, cuts, tears or other discrepancies. Inspect wheels for damage and corrosion.
- 6. Drive Motor, Brake, and Hub** - No evidence of leakage.
- 7. Hood Assemblies** - See Inspection Note.
- 8. All Hydraulic Cylinders** - No visible damage; pivot pins and hydraulic hoses undamaged, not leaking.
- 9. Turntable Bearing** - Evidence of proper lubrication. No evidence of loose bolts or looseness between bearing and machine.
- 10. Tie Rod Ends and Steering Spindles** - See Inspection Note.
- 11. Hydraulic Pump** - See Inspection Note.
- 12. Fuel Tank** - See Inspection Note.
- 13. Hydraulic Reservoir** - See Inspection Note.
- 14. Battery** - Batteries have proper electrolyte level; cables tight; see Inspection Note.
- 15. Platform Rotator** - See Inspection Note.
- 16. SkyGuard (If Equipped)** - See Inspection Note.

Function Check

Perform the Function Check as follows:

- 1.** From the ground control console with no load in the platform:
 - a.** Check that all guards protecting the switches or locks are in place;
 - b.** Operate all functions and ensure proper operation;
 - c.** Check auxiliary power and ensure proper operation;
 - d.** Ensure that all machine functions are disabled when the Emergency Stop Button is pushed in.
 - e.** Ensure all boom functions stop when the function enable switch is released.
- 2.** From the platform control console:
 - a.** Ensure that the control console is firmly secured in the proper location;
 - b.** Check that all guards protecting the switches or locks are in place;
 - c.** Operate all functions and ensure proper operation;
 - d.** Ensure that all machine functions are disabled when the Emergency Stop Button is pushed in.
 - e.** Ensure that all machine functions stop when the foot-switch is released.
- 3.** With the platform in the stowed position:
 - a.** Drive the machine on a grade, not to exceed the rated gradeability, and stop to ensure the brakes hold;
 - b.** Check that the tilt indicator is illuminated to ensure proper operation.
- 4.** Swing the boom over either of the rear tires and ensure that the Drive Orientation indicator illuminates and that the Drive Orientation Override switch must be used for the drive function to operate.

SkyGuard Function Test

NOTE: Refer to Section 4.10 for additional information on SkyGuard operation.

From the Platform Console in an area free from obstructions:

1. Operate the telescope out function.
2. Activate the SkyGuard sensor:
 - a. **SkyGuard** - Apply approximately 50 lb (222 Nm) of force to yellow bar.
 - b. **SkyGuard - SkyLine** - Press cable to break magnetic connection between the cable and right bracket.
 - c. **SkyGuard - SkyEye** - Put arm or hand in path of sensor beam.
3. Once the sensor has been activated, verify the following conditions:
 - a. Telescope out function stops and telescope in function operates for a short duration.
 - b. The horn sounds.
 - c. If equipped with a SkyGuard beacon, the beacon illuminates.

4. Disengage the SkyGuard sensor, release controls, then recycle the footswitch. Ensure normal operation is available.

NOTE: On machines equipped with SkyLine, reattach magnetic end of the cable to the bracket.

If SkyGuard remains activated after function reversal or cutout, depress and hold the SkyGuard Override Switch to allow normal use of machine functions until the sensor is disengaged.

2.3 OSCILLATING AXLE LOCKOUT TEST

NOTICE

LOCKOUT SYSTEM TEST MUST BE PERFORMED QUARTERLY, ANY TIME A SYSTEM COMPONENT IS REPLACED, OR WHEN IMPROPER SYSTEM OPERATION IS SUSPECTED.

NOTE: *Ensure boom is fully retracted, lowered, and centered between rear wheels prior to beginning lockout cylinder test.*

1. Place a 6 inches (15.2 cm) high block with ascension ramp in front of left front wheel.
2. From platform control console, start engine.
3. Place the Drive control lever to the forward position and carefully drive machine up ascension ramp until left front wheel is on top of block.
4. Carefully activate Swing control lever and position boom over right side of machine or raise the main boom enough to get it out of the transport position.
5. Place Drive control lever to Reverse and drive machine off of block and ramp.
6. Have an assistant check to see that left front or right rear wheel remains elevated in position off of ground.
7. Carefully return boom to stowed position (centered between rear wheels if swung or fully lowered if raised). When boom reaches stowed position, lockout cylinders should release and allow wheel to rest on ground, it may be necessary to activate Drive to release cylinders.
8. Place the 6 inches (15.2 cm) high block with ascension ramp in front of right front wheel.
9. Place Drive control lever to Forward and carefully drive machine up ascension ramp until right front wheel is on top of block.
10. Repeat steps 4 thru 7 to check the opposite side of the oscillating axle.
11. If lockout cylinders do not function properly, have qualified personnel correct the malfunction prior to any further operation.

SECTION 3. MACHINE CONTROLS AND INDICATORS

3.1 GENERAL

NOTICE

THE MANUFACTURER HAS NO DIRECT CONTROL OVER MACHINE APPLICATION AND OPERATION. THE USER AND OPERATOR ARE RESPONSIBLE FOR CONFORMING WITH GOOD SAFETY PRACTICES.

This section provides the necessary information needed to understand control functions.

3.2 CONTROLS AND INDICATORS

NOTE: All machines are equipped with control consoles that use symbols to indicate control functions. On ANSI machines refer to decal located on the control box guard in front of the control box or by the ground controls for these symbols and the corresponding functions.

NOTE: The indicator panels use different shaped symbols to alert the operator to different types of operational situations that could arise. The meaning of those symbols are explained below.



Indicates a potentially hazardous situation, which if not corrected, could result in serious injury or death. This indicator will be red.



Indicates an abnormal operating condition, which if not corrected, may result in machine interruption or damage. This indicator will be yellow.



Indicates important information regarding the operating condition, i.e. procedures essential for safe operation. This indicator will be green with the exception of the capacity indicator which will be green or yellow depending upon platform position.

SECTION 3 - MACHINE CONTROLS AND INDICATORS

WARNING

TO AVOID SERIOUS INJURY, DO NOT OPERATE MACHINE IF ANY CONTROL LEVERS OR TOGGLE SWITCHES CONTROLLING PLATFORM MOVEMENT DO NOT RETURN TO THE OFF POSITION WHEN RELEASED.

Ground Control Console

(See Figure 3-1., Ground Control Console and Figure 3-2., Ground Control Console with MSSO (CE Only).)

1. Indicator Panel

The Indicator Panel contains indicator lights that signal problem conditions or functions operating during machine operation.

NOTE: *The Function Enable switch must be held down in order to operate Main Boom Telescope, Tower Lift, Swing, Main Lift, Jib Lift, Platform Level Override, and Platform Rotate functions.*



2. Display Gauge

Registers the amount of time the machine has been in use, with engine running. The hourmeter registers up to 16,500 hours and cannot be reset.



CAUTION

WHEN THE MACHINE IS SHUT DOWN THE POWER/EMERGENCY STOP SWITCH MUST BE POSITIONED TO THE OFF POSITION TO PREVENT DRAINING THE BATTERIES.

3. Power/Emergency Stop Switch

A two-position red mushroom shaped switch supplies power to PLATFORM/GROUND SELECT switch when pulled out (on). When pushed in (off), power is shut off to the PLATFORM/GROUND SELECT switch.

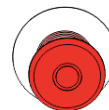

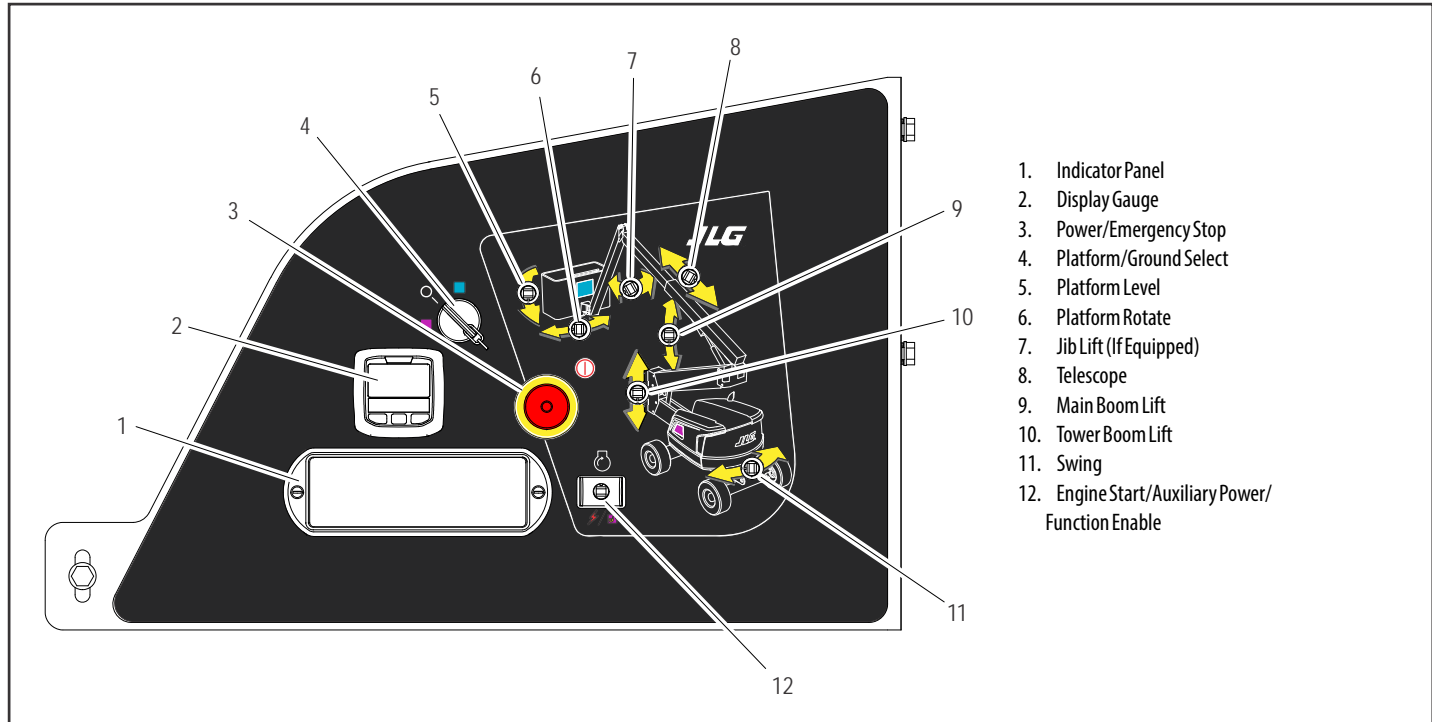

Figure 3-1. Ground Control Console

SECTION 3 - MACHINE CONTROLS AND INDICATORS

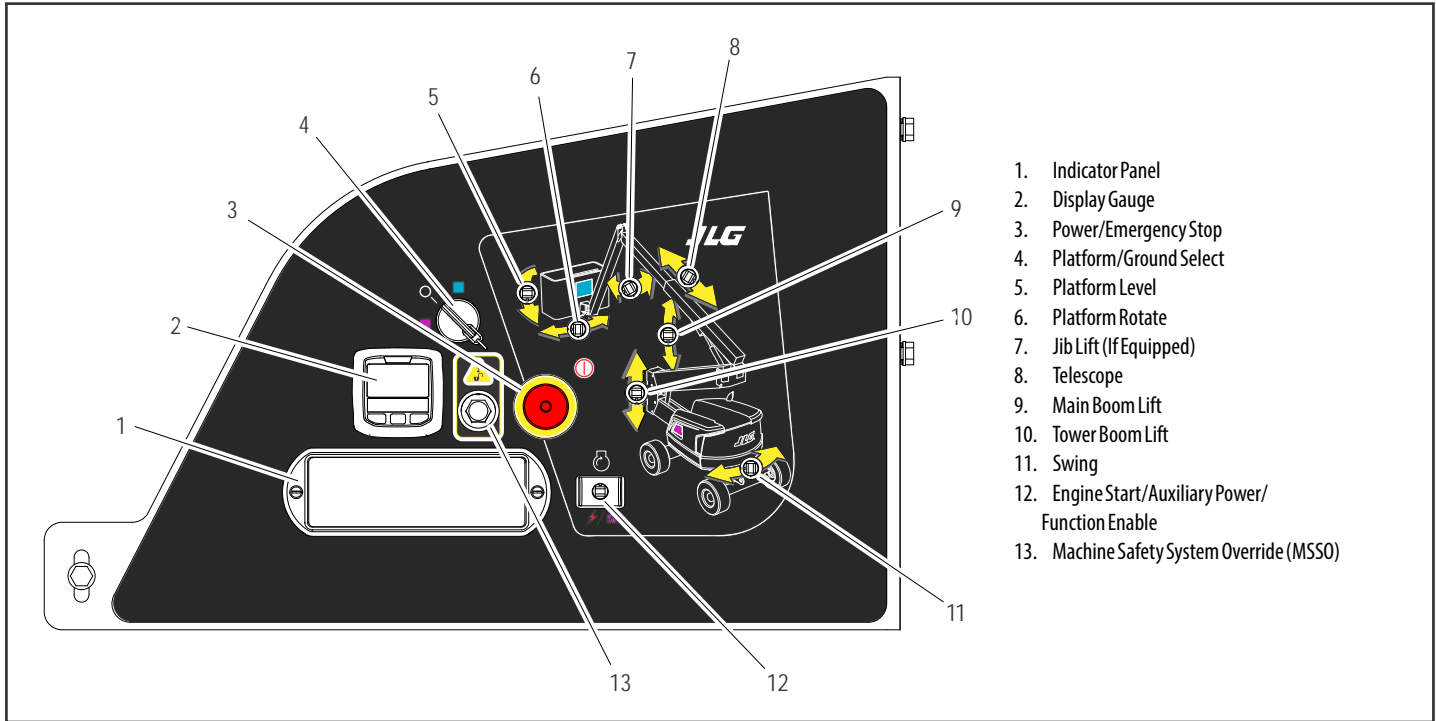

Figure 3-2. Ground Control Console with MSSO (CE Only)

NOTE: When the Platform/Ground Select Switch is in the center position, power is shut off to the controls at both operating consoles. Remove the key to prevent the controls from being actuated.

4. Platform/Ground Select Switch

The three position, key operated switch supplies power to the platform control console when positioned to PLATFORM. With the switch key turned to the GROUND position only ground controls are operable.



⚠ WARNING

ONLY USE THE PLATFORM LEVELING OVERRIDE FUNCTION FOR SLIGHT LEVELING OF THE PLATFORM. INCORRECT USE COULD CAUSE THE LOAD/OCCUPANTS TO SHIFT OR FALL. FAILURE TO DO SO COULD RESULT IN DEATH OR SERIOUS INJURY.

5. Platform Leveling Override

A three position switch allows the operator to adjust the automatic self leveling system. This switch is used to adjust platform level in situations such as ascending/descending a grade.

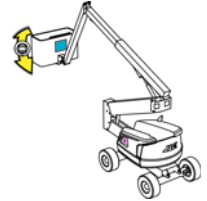

6. Platform Rotate

Provides rotation of the platform.



SECTION 3 - MACHINE CONTROLS AND INDICATORS

7. Jib Lift (If Equipped)

Provides raising and lowering of the jib.

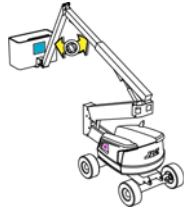

8. Telescope Control

Provides extension and retraction of the boom.



9. Main Boom Lift

Provides raising/lowering of the main boom when positioning up or down.

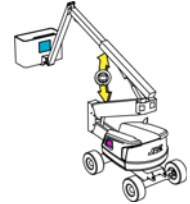

10. Tower Boom Lift

Provides raising and lowering of the tower boom.

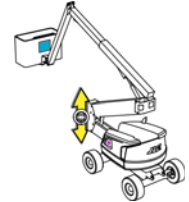

11. Swing

Provides 355 degrees non-continuous turntable rotation.

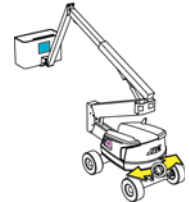

SECTION 3 - MACHINE CONTROLS AND INDICATORS

12. Engine Start/ Auxiliary Power /Function Enable

To start the engine, the switch must be held "UP" until the engine starts.

To use auxiliary power, the switch must be held "DOWN" for duration of function use.

When the engine is running, the switch must be held "DOWN" to enable all boom controls.



13. Machine Safety System Override (MSSO) (CE Only)

Provides override of function controls that are locked out such as in the event of Load Sense System activation.



SECTION 3 - MACHINE CONTROLS AND INDICATORS

Ground Control Indicator Panel

(See Figure 3-3., Ground Control Indicator Panel)

1. Battery Malfunction Indicator

Indicates a problem in the battery or charging circuit, and service is required.



2. Low Engine Oil Pressure Indicator

Indicates that engine oil pressure is below normal and service is required.



3. High Engine Temperature Indicator

Indicates that engine coolant temperature is abnormally high and service is required.



4. Engine Oil Temperature Indicator (Deutz)

Indicates that the temperature of the engine oil, which also serves as engine coolant, is abnormally high and service is required.



5. Engine Malfunction/Check Engine Indicator

Indicates that engine oil pressure is below normal or engine coolant temperature is abnormally high and service is required.



6. Low Fuel Level Indicator

Indicates the fuel level is low. The Fuel Reserve/Cut-Out System will shut the engine down (or allow it start and run for an additional minute, depending upon machine setup) before the fuel tank is emptied.



7. Glow Plug Indicator

Indicates the glow plugs are operating. After turning on ignition, wait until light goes out before cranking engine.



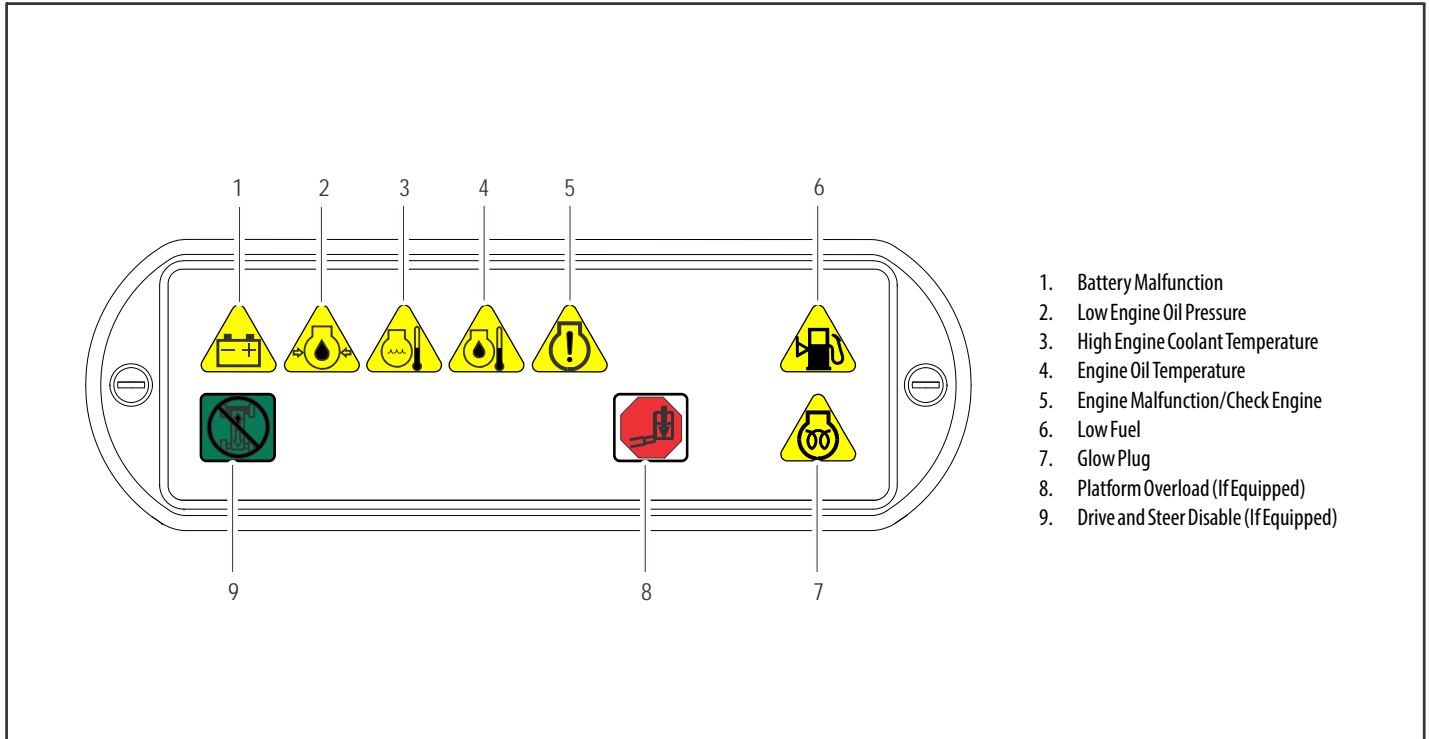

Figure 3-3. Ground Control Indicator Panel

SECTION 3 - MACHINE CONTROLS AND INDICATORS

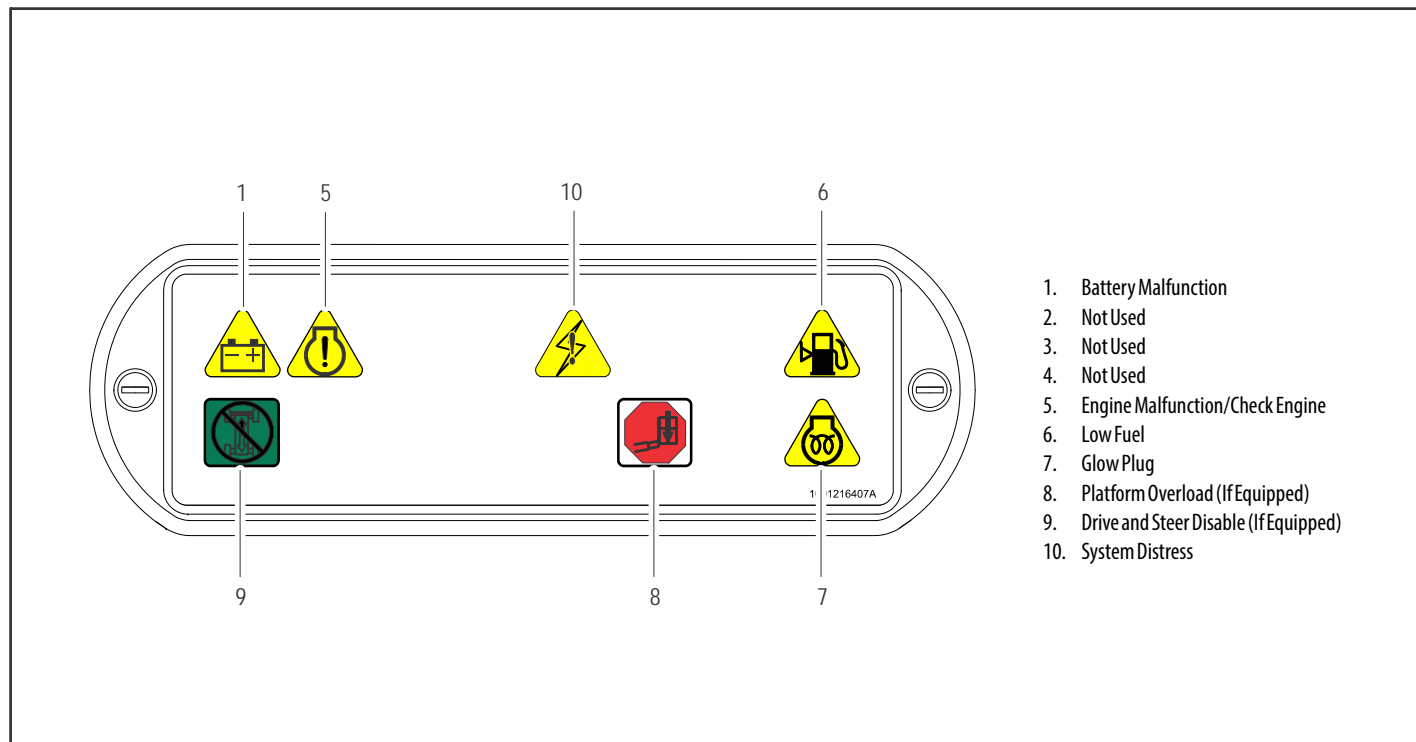

Figure 3-4. Ground Control Indicator Panel - Kubota Engine

SECTION 3 - MACHINE CONTROLS AND INDICATORS

8. Platform Overload Indicator (If Equipped)

Indicates the platform has been overloaded.



9. Drive and Steer Disable Indicator (If Equipped)

Indicates the Drive and Steer Disable function has been activated.



10. System Distress Indicator

The light indicates that the JLG Control System has detected an abnormal condition and a Diagnostic Trouble Code has been set in the system memory. Refer to the Service Manual for instructions concerning the trouble codes and trouble code retrieval.



The system distress indicator light will illuminate for 2-3 seconds when the key is positioned to the on position to act as a self test.

Ground Control Console Display Gauge

(See Figure 3-8., Ground Control Console Display Gauge)

The Display Gauge shows engine hours, fuel level (if applicable), and Diagnostic Trouble Codes (DTCs) from both the JLG Control System and the engine control system. During machine start up, with no active DTCs in the control system, the splash screen will show for 3 seconds and then switch to main screen. If there is an active DTC while powering up the machine, the splash screen will show for 3 seconds, and then launch the Diagnostics Screen. The indicator lamp will light when there is an active DTC in the Fault Log.



Figure 3-5. Splash Screen

SECTION 3 - MACHINE CONTROLS AND INDICATORS

The Diagnostic Screen will show active and inactive faults from the JLG Control System on the screen. An asterisk (*) will be displayed to show active faults.

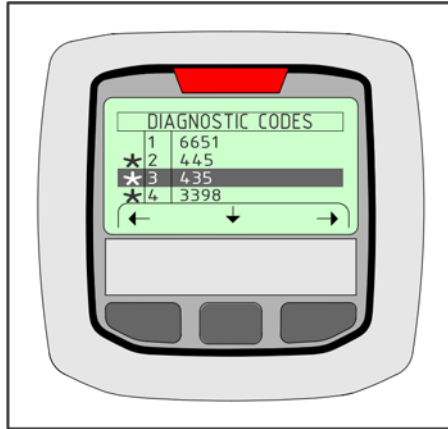

Figure 3-6. Diagnostic Screen

The Engine Diagnostics Screen will show SPN (Suspect Parameter Number), FMI (Failure Mode Identifier), and Occurrence count information. Engine SPN text is not scrollable. If there is more than one engine trouble code, the operator must exit from the Engine DTC Screen to see other SPN and FMI information.

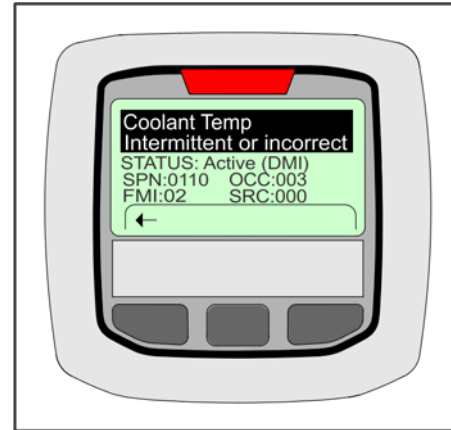

Figure 3-7. Engine Diagnostic Screen

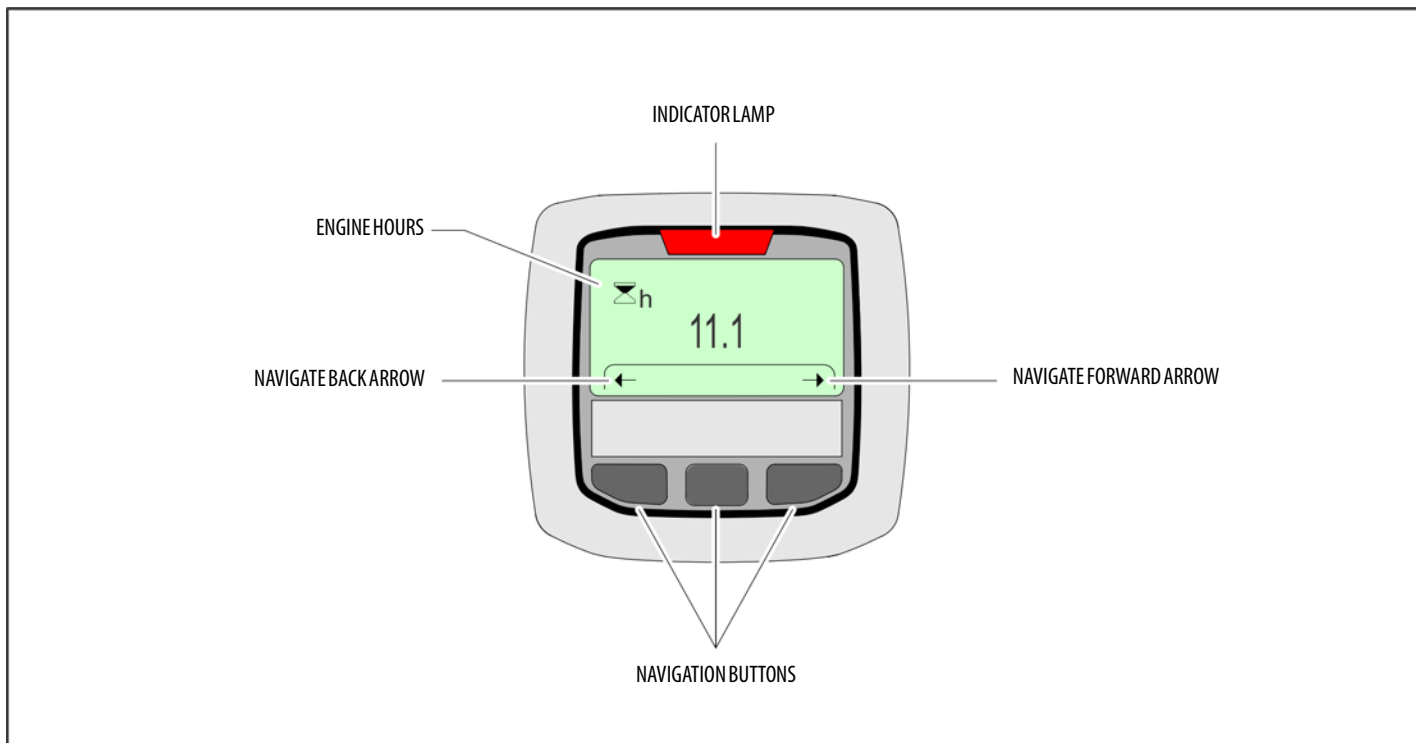

Figure 3-8. Ground Control Console Display Gauge

Platform Console

(See Figure 3-9., Platform Control Console)

⚠ WARNING

TO AVOID SERIOUS INJURY, DO NOT OPERATE MACHINE IF ANY CONTROL LEVERS OR TOGGLE SWITCHES CONTROLLING PLATFORM MOVEMENT DO NOT RETURN TO THE OFF OR NEUTRAL POSITION WHEN RELEASED.

1. Drive Speed Switch

The forward position gives maximum drive speed. The back position gives maximum torque for rough terrain and climbing grades. The center position allows the machine to be driven as quietly as possible.

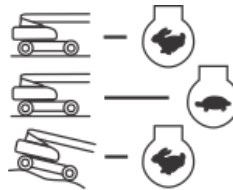

⚠ WARNING

ONLY USE THE PLATFORM LEVELING OVERRIDE FUNCTION FOR SLIGHT LEVELING OF THE PLATFORM. INCORRECT USE COULD CAUSE THE LOAD/OCCUPANTS TO SHIFT OR FALL. FAILURE TO DO SO COULD RESULT IN DEATH OR SERIOUS INJURY.

2. Platform Leveling Override

A three position switch allows the operator to adjust the automatic self leveling system. This switch is used to adjust platform level in situations such as ascending/descending a grade.

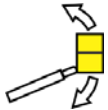

3. Fuel Select (Dual Fuel Engine Only) (If Equipped)

Moving the switch to the appropriate position selects gasoline or liquid propane fuel.



4. Horn

A push-type HORN switch supplies electrical power to an audible warning device when pressed.



SECTION 3 - MACHINE CONTROLS AND INDICATORS

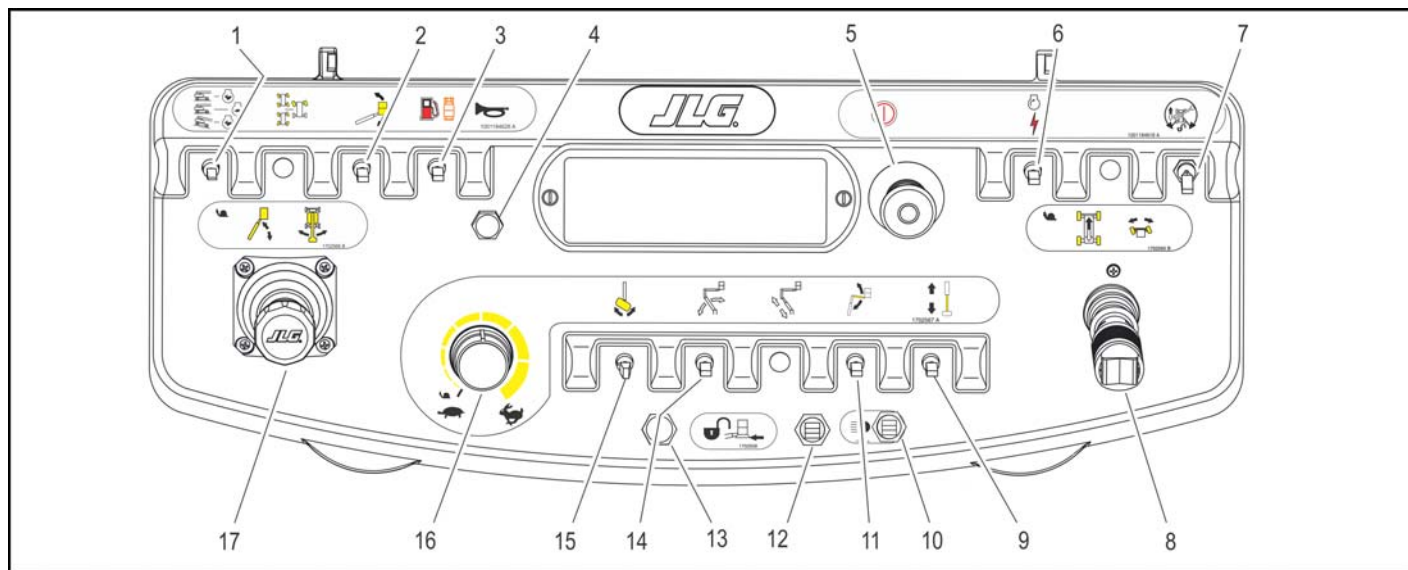

- | | | | |
|-------------------------------|-------------------------------|---|--------------------------------|
| 1. Drive Speed/Torque Select | 6. Start/Auxiliary Power | 10. Lights (If Equipped) | 14. Tower Boom Lift |
| 2. Platform Leveling Override | 7. Drive Orientation Override | 11. Jib Lift (If Equipped) | 15. Platform Rotate |
| 3. Fuel Select | 8. Drive/Steer | 12. Soft Touch/SkyGuard Override (If Equipped) | 16. Function Speed Control |
| 4. Horn | 9. Telescope | 13. Soft Touch/SkyGuard Indicator (If Equipped) | 17. Main Lift/Swing Controller |
| 5. Power/Emergency Stop | | | |

Figure 3-9. Platform Control Console

5. Power/Emergency Stop Switch

A two-position red mushroom shaped switch furnishes power to PLATFORM Controls when pulled out (on). When pushed in (off), power is shut off to the platform functions.



6. Start/Auxiliary Power

When pushed forward, the switch energizes the starter motor to start the engine.



The Auxiliary Power control switch energizes the electrically operated hydraulic pump. (Switch must be held ON for duration of auxiliary pump use.)



The auxiliary pump functions to provide sufficient oil flow to operate the basic machine functions should the main pump or engine fail. The auxiliary pump will operate tower boom lift, tower telescope, main boom lift, main telescope and swing.

7. Drive Orientation Override

When the boom is swung over the rear tires or further in either direction, the Drive Orientation indicator will illuminate when the drive function is selected. Push and release the switch, and within 3 seconds move the Drive/Steer control to activate drive or steer. Before driving, locate the black/white orientation arrows on both the chassis and the platform controls. Move the drive controls in a direction matching the directional arrows for the intended direction of travel.



NOTE: To operate the Drive joystick, pull up on the locking ring below the handle.

NOTE: The Drive joystick is spring loaded and will automatically return to neutral (off) position when released.

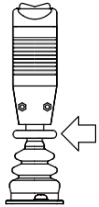

8. Drive/Steer

Push forward to drive forward, pull back to drive in reverse. Steering is accomplished via a thumb-activated rocker switch on the end of the steer handle.

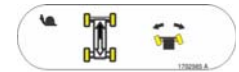

SECTION 3 - MACHINE CONTROLS AND INDICATORS

9. Telescope

Provides extension and retraction of the main boom.

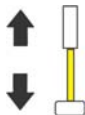

10. Lights (If Equipped)

This switch operates the chassis lights if the machine is so equipped.



11. Jib Lift (If Equipped)

Provides for raising or lowering of the jib by positioning up/down.

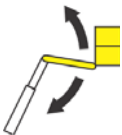

12. Soft Touch/SkyGuard Override Switch (If Equipped)

The machine can be equipped with one of three options. It may have Soft Touch, SkyGuard, or both Soft Touch and SkyGuard.

If equipped with Soft Touch, the switch enables the functions that were cut out by the Soft Touch system to operate again at creep speed, allowing the operator to move the platform away from the obstacle that caused the shutdown situation.



If equipped with SkyGuard, the switch enables functions cut out by the SkyGuard system to be operated again, allowing the operator to resume use of machine functions.



If equipped with both Soft Touch and SkyGuard, the switch operates like described above and allows the operator to override the system that has experienced a cutout situation.



13. Soft Touch/SkyGuard Indicator (If Equipped)

Indicates the Soft Touch bumper is against an object or the SkyGuard sensor has been activated. All controls are cut out until the override button is pushed. For Soft Touch, controls are then active in the Creep Mode or for SkyGuard, controls will work normally.

When Soft Touch is active, the indicator will be on continuously and the alarm will sound. When SkyGuard is active, the indicator will flash, and the horn will sound continuously.

SECTION 3 - MACHINE CONTROLS AND INDICATORS

14. Tower Boom Lift

Provides for raising and lowering of tower boom when positioned up or down.

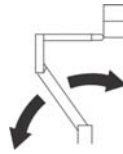

15. Platform Rotate

Provides rotation of the platform when positioned to the right or left.



16. Function Speed Control

This control affects the speed of telescope, tower lift and jib lift. Turning the knob all the way counterclockwise until it clicks puts drive, **main** lift and swing into creep mode.



NOTE: To operate the Main Boom Lift/Swing joystick, pull up on the locking ring below the handle.

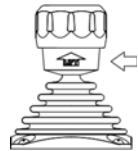

NOTE: The Main Boom Lift/Swing joystick is spring loaded and will automatically return to neutral (off) position when released.

17. Main Lift/Swing Controller

Provides main lift and swing. Push forward to lift up, pull backward to boom down. Move right to swing right, move left to swing left. Moving the joystick activates switches to provide the functions selected.



SECTION 3 - MACHINE CONTROLS AND INDICATORS

Platform Control Indicator Panel

(See Figure 3-10., Platform Control Indicator Panel)

NOTE: *The indicator lights will illuminate for approximately 1 second when the key is positioned to the on position to act as a self test.*

1. AC Generator (If Equipped)

Indicates the generator is in operation.



2. Platform Overload Indicator (If Equipped)

Indicates the platform has been overloaded.



3. Tilt Alarm Warning Light and Alarm



This red illuminator indicates that the chassis is on a slope. An alarm will also sound when the chassis is on an excessive slope and the boom is out of transport position. If lit when boom is out of transport position, lower to below horizontal then reposition machine so that it is level before continuing operation. If the boom is above horizontal and the machine is on a slope, the tilt alarm warning light will illuminate and an alarm will sound and CREEP is automatically activated.

Tilt Angle	Market
5°	All Markets

⚠ WARNING

IF TILT WARNING LIGHT IS ILLUMINATED WHEN BOOM IS RAISED OR EXTENDED, RETRACT AND LOWER TO BELOW HORIZONTAL THEN REPOSITION MACHINE SO THAT IT IS LEVEL BEFORE EXTENDING BOOM OR RAISING BOOM ABOVE HORIZONTAL.

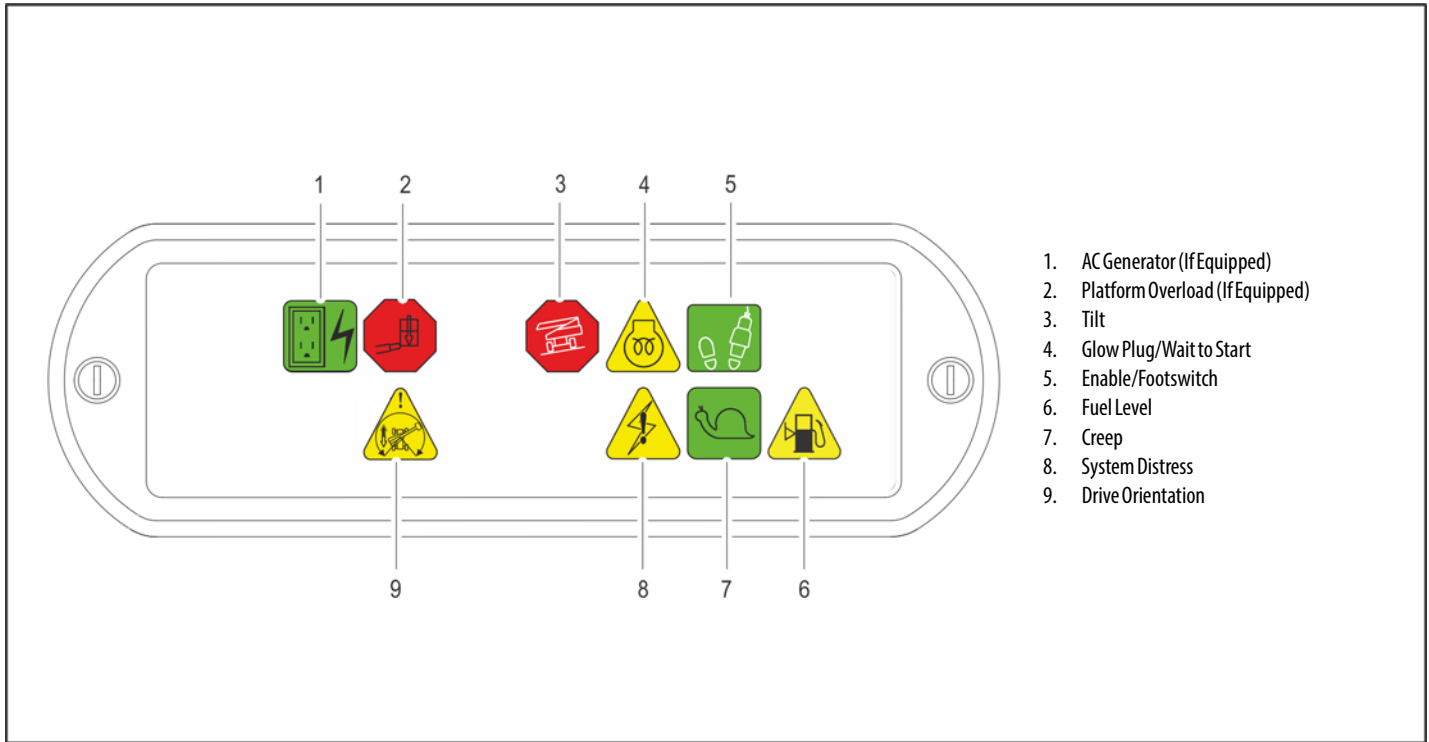

Figure 3-10. Platform Control Indicator Panel

SECTION 3 - MACHINE CONTROLS AND INDICATORS

4. Glow Plug/Wait to Start Indicator

Indicates the glow plugs are operating. After turning on ignition, wait until light goes out before starting engine.



5. Enable Indicator/Footswitch

To operate any function, the footswitch must be depressed and the function selected within seven seconds. The enable indicator shows that the controls are enabled. If a function is not selected within seven seconds, or if a seven second lapse between ending one function and beginning the next function, the enable light will go out and the footswitch must be released and depressed again to enable the controls.



Releasing the footswitch removes power from all controls and applies the drive brakes.

WARNING

TO AVOID SERIOUS INJURY, DO NOT REMOVE, MODIFY OR DISABLE THE FOOTSWITCH BY BLOCKING OR ANY OTHER MEANS.

WARNING

FOOTSWITCH MUST BE ADJUSTED IF FUNCTIONS ACTIVATE WHEN SWITCH ONLY OPERATES WITHIN LAST 1/4" OF TRAVEL, TOP OR BOTTOM.

6. Fuel Level Indicator

Indicates a low fuel condition in the tank.



7. Creep Speed Indicator

When the Function Speed Control is turned to the creep position, the indicator acts as a reminder that all functions are set to the slowest speed. The light will be on continuously if the operator selects creep speed or if the control system puts the machine into creep speed. In addition, if the control system puts one or more individual functions in creep speed, the indicator flashes when that function is selected.



8. System Distress Indicator

The light indicates that the JLG Control System has detected an abnormal condition and a Diagnostic Trouble Code has been set in the system memory. Refer to the Service Manual for instructions concerning the trouble codes and trouble code retrieval.



9. Drive Orientation Indicator

When the boom is swung beyond the rear drive tires or further in either direction, the Drive Orientation indicator will illuminate when the drive function is selected. This is a signal for the operator to verify that the drive control is being operated in the proper direction (i.e. controls reversed situations).



SECTION 4. MACHINE OPERATION

4.1 DESCRIPTION

This machine is a mobile elevating work platform used to position personnel, along with their necessary tools and materials at work locations.

The primary operator control console is in the platform. From this control console, the operator can drive and steer the machine in both forward and reverse directions. The operator can raise or lower the boom or swing the boom to the left or right. Standard boom swing is 355 degree non-continuous. The machine has a Ground Control Console which will override the Platform Control Console. Ground Controls operate all functions except drive and steer and are to be used in an emergency to lower the platform to the ground should the operator in the platform be unable to do so.

4.2 BOOM OPERATING CHARACTERISTICS AND LIMITATIONS

Capacities

Raising boom above horizontal with or without any load in platform, is based on the following criteria:

1. Machine is positioned on a smooth, firm and level surface.
2. Load is within manufacturers rated design capacity.
3. All machine systems are functioning properly.
4. Machine is as originally equipped from JLG.

Stability

Machine stability is based on two (2) conditions which are called FORWARD and BACKWARD stability. The machine's position of least FORWARD stability is shown in Figure 4-1., and its position of least BACKWARD stability is shown in Figure 4-2.



TO AVOID FORWARD OR BACKWARD TIPPING, DO NOT OVERLOAD MACHINE OR OPERATE THE MACHINE ON AN OUT-OF-LEVEL SURFACE.

4.3 ENGINE OPERATION

NOTE: Initial starting must always be performed from the Ground Control station.



Starting Procedure

CAUTION

IF ENGINE FAILS TO START PROMPTLY, DO NOT CRANK FOR AN EXTENDED TIME. SHOULD ENGINE FAIL TO START AGAIN, ALLOW STARTER TO “COOL OFF” FOR 2-3 MINUTES. IF ENGINE FAILS AFTER SEVERAL ATTEMPTS, REFER TO ENGINE MAINTENANCE MANUAL.

NOTE: Diesel engines only: After turning on ignition, operator must wait until glow plug indicator light goes out before cranking engine.



1. Turn key of Platform/Ground Select switch to Ground.



2. Pull the Power/Emergency Stop switch to On.



3. Push the Engine Start switch until engine starts.



CAUTION

ALLOW ENGINE TO WARM-UP FOR A FEW MINUTES AT LOW SPEED BEFORE APPLYING ANY LOAD.

4. After engine has had sufficient time to warm up, push in the Power/Emergency Stop switch and shut engine off.



5. Turn Platform/Ground Select switch to Platform.



SECTION 4 - MACHINE OPERATION

6. Pull out the Ground Console Power/Emergency Stop switch to provide power to the platform controls.



7. From Platform, pull Power/Emergency Stop switch out.



8. Push the Engine Start switch until engine starts.



NOTE: Footswitch must be in released (up) position before starter will operate. If starter operates with footswitch in the depressed position, DO NOT OPERATE MACHINE.

Shutdown Procedure

CAUTION

IF AN ENGINE MALFUNCTION CAUSES AN UNSCHEDULED SHUTDOWN, DETERMINE THE CAUSE AND CORRECT IT BEFORE RESTARTING THE ENGINE.

1. Remove all load and allow engine to operate at low speed for 3-5 minutes; this allows further reduction of internal engine temperature.

2. Push Power/Emergency Stop switch in.

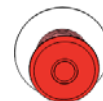

3. Turn Platform/Ground Select switch to Off.

Refer to Engine Manufacturer's manual for detailed information.



Fuel Reserve / Shut-Off System

NOTE: Reference the Service and Maintenance Manual along with a qualified JLG Mechanic to verify your machine setup.

The Fuel Shutoff System monitors the fuel in the tank and senses when the fuel level is getting low. The JLG Control System automatically shuts the engine down before the fuel tank is emptied unless the machine is set up for Engine Restart.



If fuel level reaches the Empty range, the Low Fuel light will begin to flash once a second and there will be approximately 60 minutes of engine run time left. If the system is in this condition and automatically shuts down the engine or if the operator manually shuts down the engine before the 60 minute run time is complete, the Low Fuel light will flash 10 times a second and the engine will react according to machine setup. Setup options are as follows:

- Engine One Restart - When the engine shuts down, the operator will be permitted to cycle power and restart the engine once with approximately 2 minutes of run time. After the 2 minute run time is complete or if the engine is shut down by the operator prior to the completion of the 2 minute run time, it cannot be restarted until fuel is added to the tank.

- Engine Restart - When the engine shuts down, the operator will be permitted to cycle power and restart the engine for approximately 2 minutes of run time. After the 2 minutes of run time is complete, the operator may cycle power and restart the engine for an additional 2 minutes of run time. The operator can repeat this process until there is no more fuel available.
- Engine Stop - When the engine shuts down, no restarts will be permitted until fuel is added to the tank.

SECTION 4 - MACHINE OPERATION

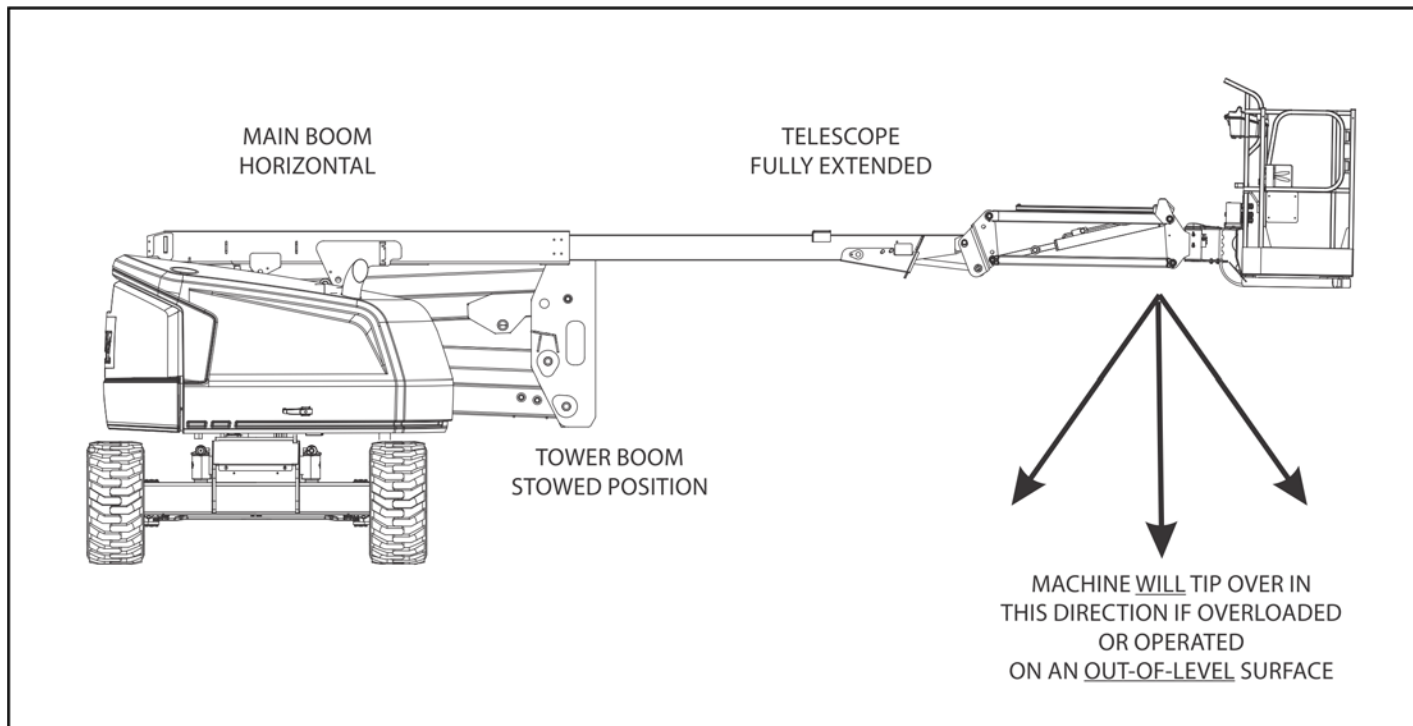

Figure 4-1. Position of Least Forward Stability

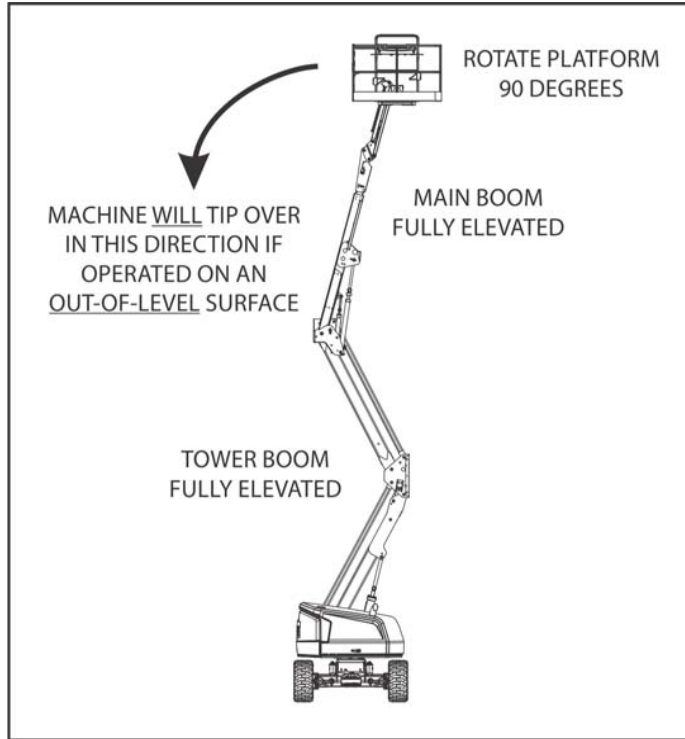

Figure 4-2. Position of Least Backward Stability

4.4 TRAVELING (DRIVING)

See Figure 4-3., Grade and Side Slopes

NOTE: *Refer to the Operating Specifications table for Gradeability and Sideslope ratings.*

All ratings for Gradeability and Sideslope are based upon the machine's boom being in the stowed position, fully lowered, and retracted.

Traveling is limited by two factors:

1. Gradeability, which is the percent of grade of the incline the machine can climb.
2. Sideslope, which is the angle of the slope the machine can be driven across.

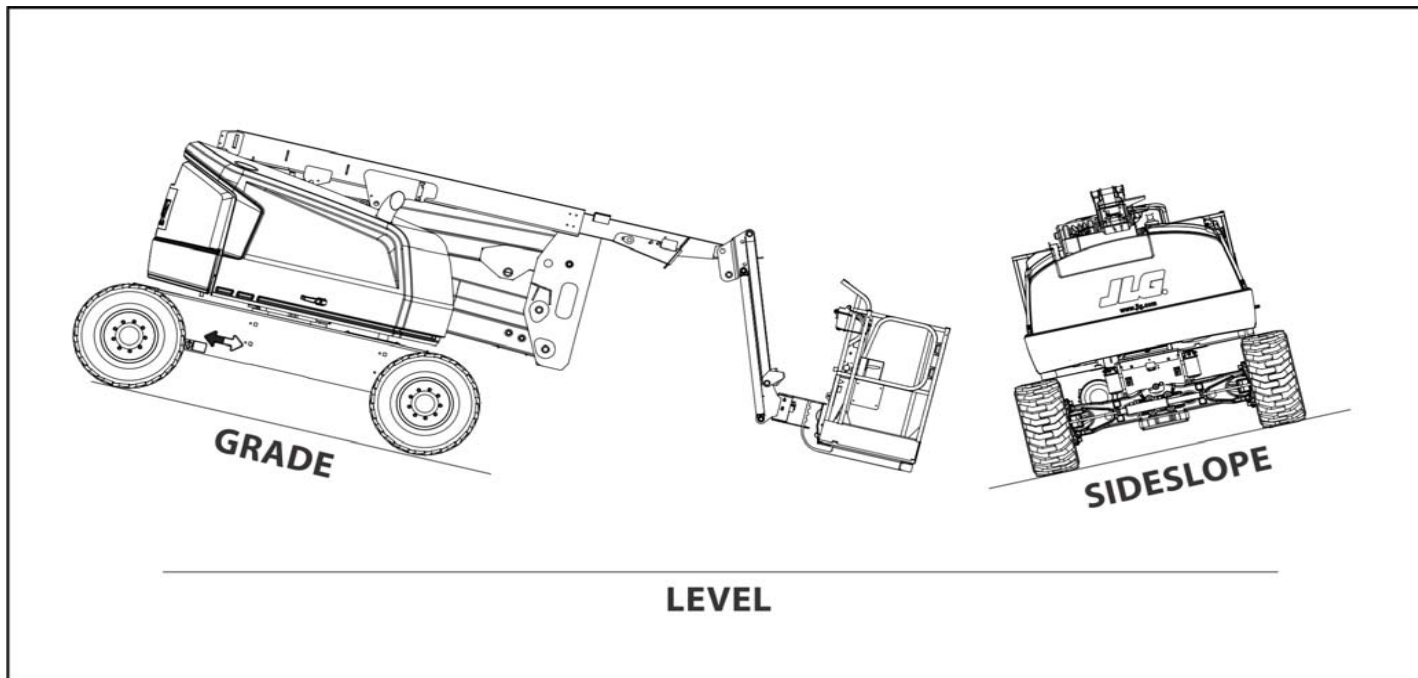

Figure 4-3. Grade and Side Slopes

⚠ WARNING

DO NOT DRIVE WITH BOOM OUT OF TRANSPORT MODE EXCEPT ON A SMOOTH, FIRM AND LEVEL SURFACE.

TO AVOID LOSS OF TRAVEL CONTROL OR "TIP OVER", DO NOT DRIVE MACHINE ON GRADES EXCEEDING THOSE SPECIFIED IN THE OPERATING SPECIFICATIONS SECTION OF THIS MANUAL.

DO NOT DRIVE ON SIDESLOPES WHICH EXCEED 5 DEGREES.

USE EXTREME CAUTION WHEN DRIVING IN REVERSE AND AT ALL TIMES WHEN THE PLATFORM IS ELEVATED.

BEFORE DRIVING, LOCATE THE BLACK/WHITE ORIENTATION ARROWS ON BOTH THE CHASSIS AND THE PLATFORM CONTROLS. MOVE THE DRIVE CONTROLS IN A DIRECTION MATCHING THE DIRECTIONAL ARROWS FOR THE INTENDED DIRECTION OF TRAVEL.

Traveling Forward and Reverse

1. At Platform Controls, pull out Emergency Stop switch, start the engine, and activate foot-switch.

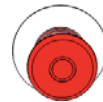

2. Position Drive controller to Forward or Reverse as desired.

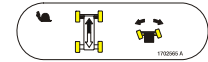

This machine is equipped with a Drive Orientation Indicator. The yellow light on the platform control console indicates that the boom is swung beyond the rear drive tires and the machine may Drive/Steer in the opposite direction from the movement of the controls. If the indicator is illuminated, operate the Drive function in the following manner:

1. Match the black and white direction arrows on both platform control console and the chassis to determine the direction the machine will travel.

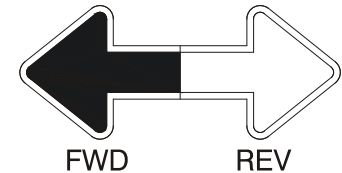

2. Push and release the Drive Orientation Override switch. Within 3 seconds, slowly move the Drive control toward the arrow matching the intended direction of machine travel. The indicator light will flash during the 3 second interval until the drive function is selected.

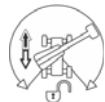

Traveling on a Grade

When traveling a grade, maximum braking and traction are obtained with the boom stowed, in position over the rear (drive) axle, and in line with the direction of travel. Drive the machine forward when climbing a grade, and in reverse when descending a grade. Do not exceed the machine's maximum rated gradability.

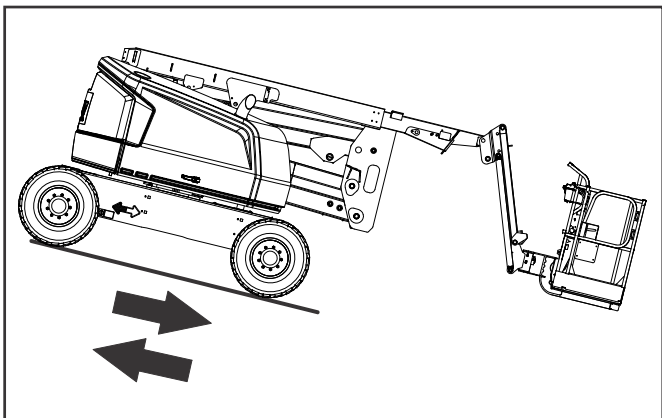

Figure 4-4. Traveling on a Grade

NOTICE

IF THE BOOM IS OVER THE FRONT (STEER) AXLE, DIRECTION OF STEER AND DRIVE MOVEMENT WILL BE OPPOSITE FROM THE MOVEMENT OF THE CONTROLS.

4.5 STEERING

Position thumb switch on Drive/Steer controller to Right for steering right, or to Left for steering left.



4.6 PLATFORM

Platform Level Adjustment

WARNING

ONLY USE THE PLATFORM LEVELING OVERRIDE FUNCTION FOR SLIGHT LEVELING OF THE PLATFORM. INCORRECT USE COULD CAUSE THE LOAD/OCCUPANTS TO SHIFT OR FALL. FAILURE TO DO SO COULD RESULT IN DEATH OR SERIOUS INJURY.

To Level Up or Down - Position the Platform/Level control switch Up or Down and hold until the platform is level.

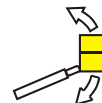

Platform Rotation

To rotate the platform to the left or right, use the Platform Rotate control switch to select the direction and hold until desired position is reached.



4.7 BOOM

⚠ WARNING

A RED TILT WARNING LIGHT IS LOCATED ON THE CONTROL CONSOLE WHICH LIGHTS WHEN THE CHASSIS IS ON AN EXCESSIVE SLOPE. DO NOT SWING OR RAISE BOOM ABOVE HORIZONTAL WHEN LIGHT IS LIT.

DO NOT DEPEND ON TILT ALARM AS A LEVEL INDICATOR FOR THE CHASSIS. TILT ALARM INDICATES CHASSIS IS ON AN EXCESSIVE SLOPE (5 DEGREES OR GREATER). CHASSIS MUST BE LEVEL BEFORE SWINGING, OR RAISING BOOM ABOVE HORIZONTAL OR DRIVING WITH THE BOOM ELEVATED.

TO AVOID TIP OVER IF RED TILT WARNING LIGHT LIGHTS WHEN BOOM IS RAISED ABOVE HORIZONTAL, LOWER PLATFORM TO GROUND LEVEL. THEN REPOSITION MACHINE SO THAT CHASSIS IS LEVEL BEFORE RAISING BOOM.

TRAVELING WITH BOOM BELOW HORIZONTAL IS PERMITTED ON GRADES AND SIDE SLOPES SPECIFIED IN THE OPERATING SPECIFICATIONS SECTION OF THIS MANUAL.

⚠ WARNING

TO AVOID SERIOUS INJURY, DO NOT OPERATE MACHINERY IF ANY CONTROL LEVER OR TOGGLE SWITCH CONTROLLING PLATFORM MOVEMENT DOES NOT RETURN TO THE 'OFF' OR NEUTRAL POSITION WHEN RELEASED.

⚠ CAUTION

TO AVOID A COLLISION AND INJURY IF PLATFORM DOES NOT STOP WHEN A CONTROL SWITCH OR LEVER IS RELEASED, REMOVE FOOT FROM FOOTSWITCH OR USE EMERGENCY STOP SWITCH TO STOP THE MACHINE.

Swinging the Boom

To swing boom, use Swing control switch to select Right or Left direction.



Raising and Lowering the Tower Boom

To raise or lower the Tower Boom, position Tower Boom Lift switch to Up or Down until desired height is reached.



Raising and Lowering the Main Boom

To raise or lower the Main Boom, use Main Boom Lift controller to select UP or DOWN movement.



Telescoping the Main Boom

To extend or retract the main boom, use the Main Telescope Control Switch to select IN or OUT movement.

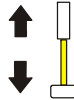

4.8 FUNCTION SPEED CONTROL

This control affects the speed of telescope, tower boom lift and jib lift. Turning the knob all the way counterclockwise until it clicks puts drive, main lift, platform rotate, and swing into creep mode.



4.9 MACHINE SAFETY SYSTEM OVERRIDE (MSSO)(CE ONLY)

The Machine Safety System Override (MSSO) is used to override function controls for Emergency Platform Retrieval only. Refer to Section 5.5, Machine Safety System Override (MSSO)(CE Only)for operating procedures.



4.10 SKYGUARD OPERATION

SkyGuard provides enhanced control panel protection. When the SkyGuard sensor is activated, functions in use at the time of activation will reverse or cutout. The SkyGuard Function Table provides more details on these functions.

During activation, the horn will sound and, if equipped with a SkyGuard beacon, the beacon will illuminate until sensor and footswitch are disengaged.

If the SkyGuard sensor remains activated after function reversal or cutout, depress and hold the SkyGuard Override Switch to allow normal functions until the sensor is disengaged.

Consult the following illustrations to determine which type of SkyGuard the machine has. Regardless of type, SkyGuard function according to the SkyGuard Function Table does not change.

SkyGuard

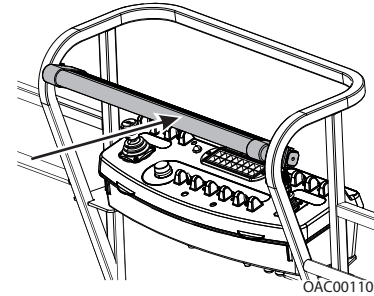

Approximately 50 lb (222 Nm) of force is applied to yellow bar.

SkyGuard - SkyLine

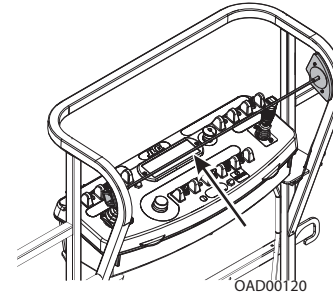

Cable is pressed, breaking the magnetic connection between the cable and right bracket.

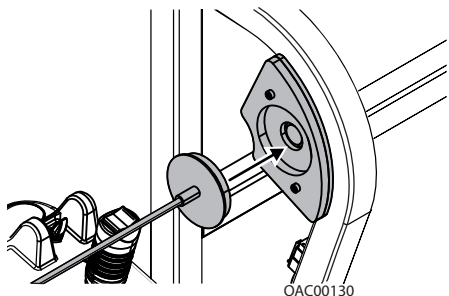

Reattach magnetic end of cable to bracket if it becomes disconnected.

SkyGuard - SkyEye

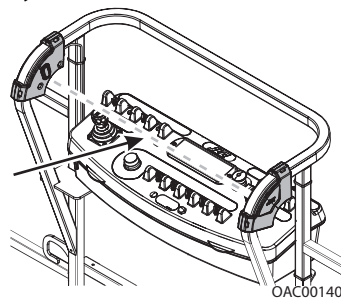

Operator passes through path of sensor beam.

SkyGuard Function Table

Drive Forward	Drive Reverse	Steer	Swing	Tower Lift Up	Tower Lift Down	Boom Lift Up	Boom Lift Down	Boom Tele Out	Boom Tele In	Jib Lift	Basket Level	Basket Rotate
R*/C**	R	C	R	R	C	R	R	R	C	C	C	C
R = Indicates Reversal is Activated												
C = Indicates Cutout is Activated												
* DOS (Drive Orientation System) Enabled												
** DOS Not Enabled, machine is driving straight without steering, and any other hydraulic function is active												

4.11 SHUT DOWN AND PARK

Shut Down and Park

The procedures to shut down and park the machine are as follows:

1. Drive machine to a reasonably well protected area.
2. Ensure boom is lowered over rear drive axle.
3. Shut down Emergency Stop at Platform Controls.
4. Shut down Emergency Stop at Ground Controls. Position Platform/Ground Select switch to center OFF.
5. If necessary, cover Platform Controls to protect instruction placards, warning decals, and operating controls from hostile environment.

4.12 LIFTING AND TIE DOWN

(See Figure 4-5.)

Lifting

1. Refer to the Serial Number Plate, refer to the Specifications section of this manual, or weigh the individual unit to find out the Gross Vehicle Weight.
2. Place the boom in the stowed position.
3. Remove all loose items from the machine.
4. Properly adjust the rigging to prevent damage to the machine and so the machine remains level.

Tie Down

NOTICE

WHEN TRANSPORTING THE MACHINE IN THE STOWED POSITION, THE BOOM MUST BE FULLY LOWERED INTO THE BOOM REST.

1. Place the boom in the stowed position or storage position.
2. Remove all loose items from the machine.
3. Secure the chassis and the platform using straps or chains of adequate strength.

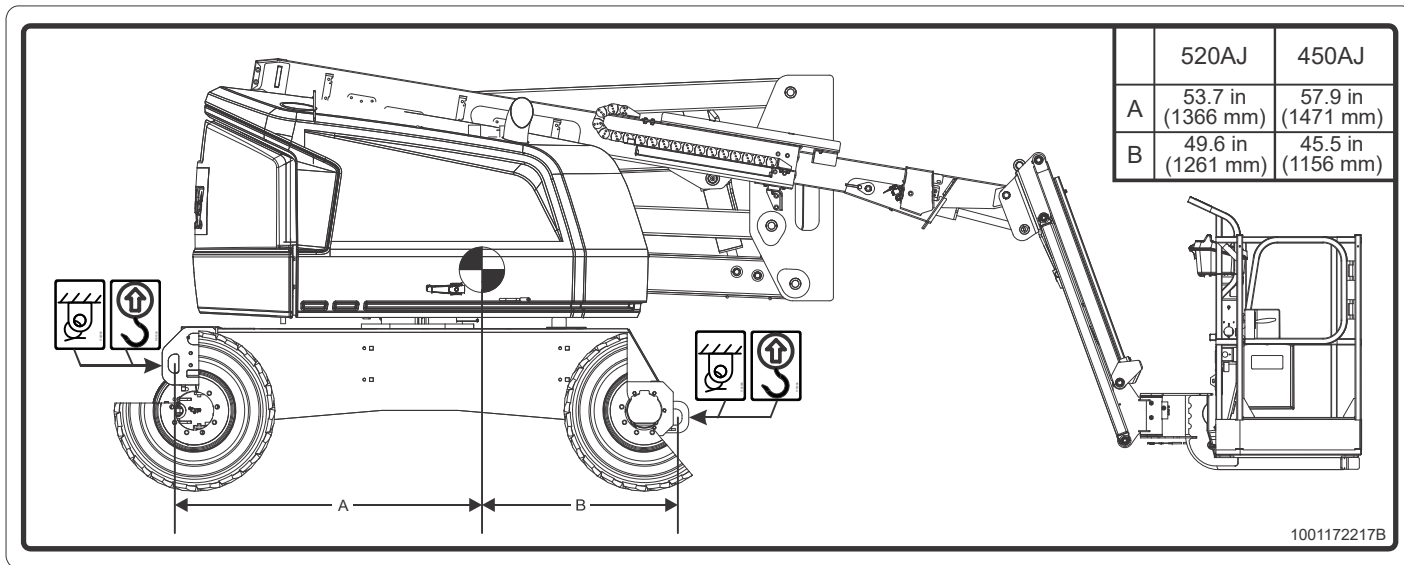

Figure 4-5. Lifting and Tie Down Chart

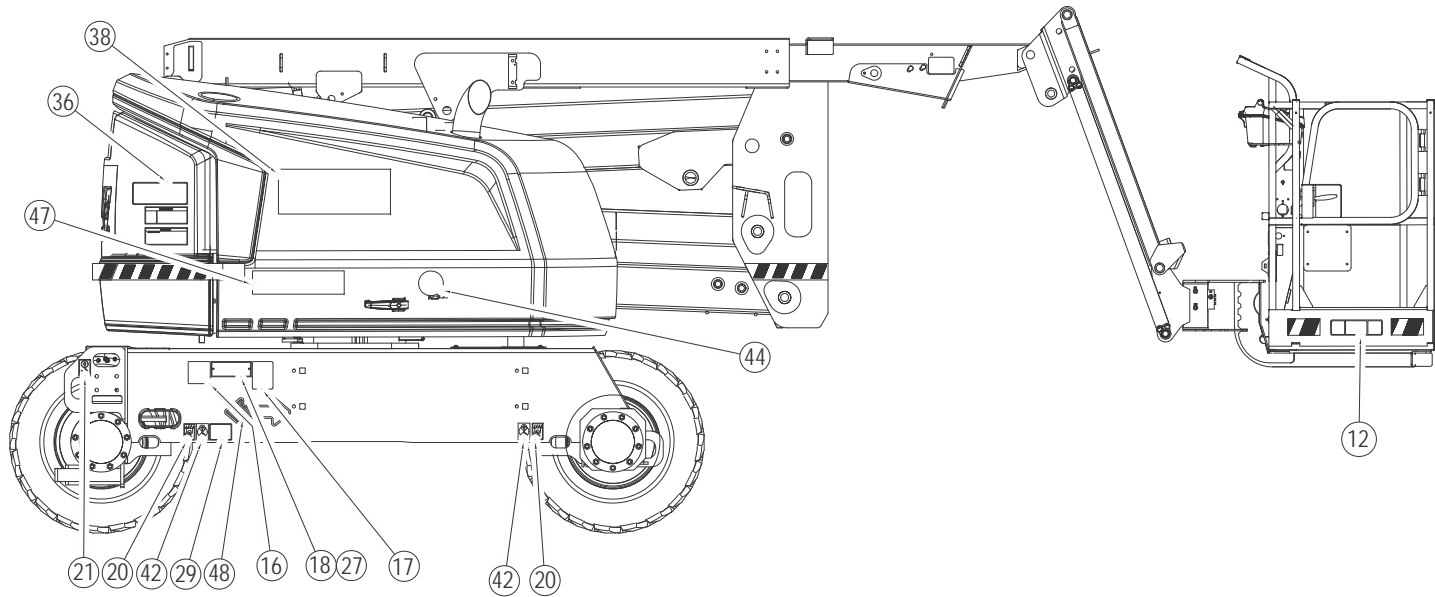

Figure 4-6. Decal Location Sheet 1 of 6

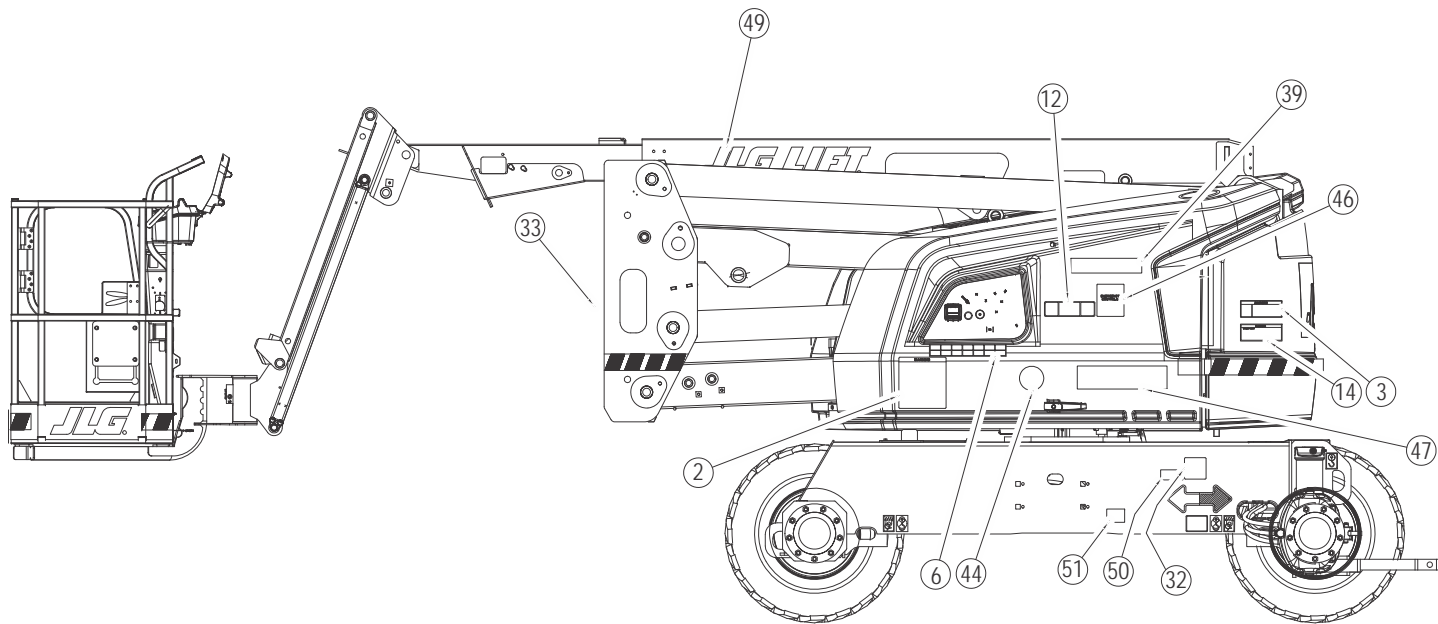

Figure 4-7. Decal Location Sheet 2 of 6

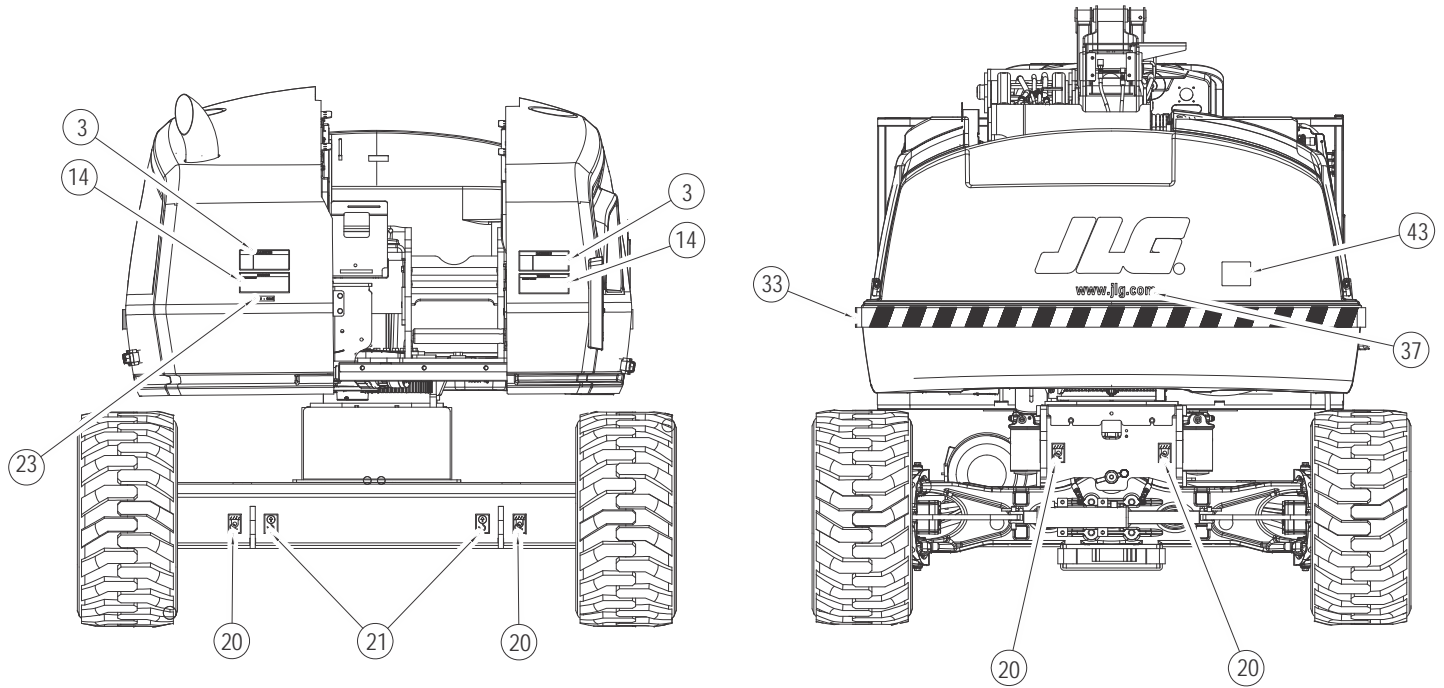

Figure 4-8. Decal Location Sheet 3 of 6

SECTION 4 - MACHINE OPERATION

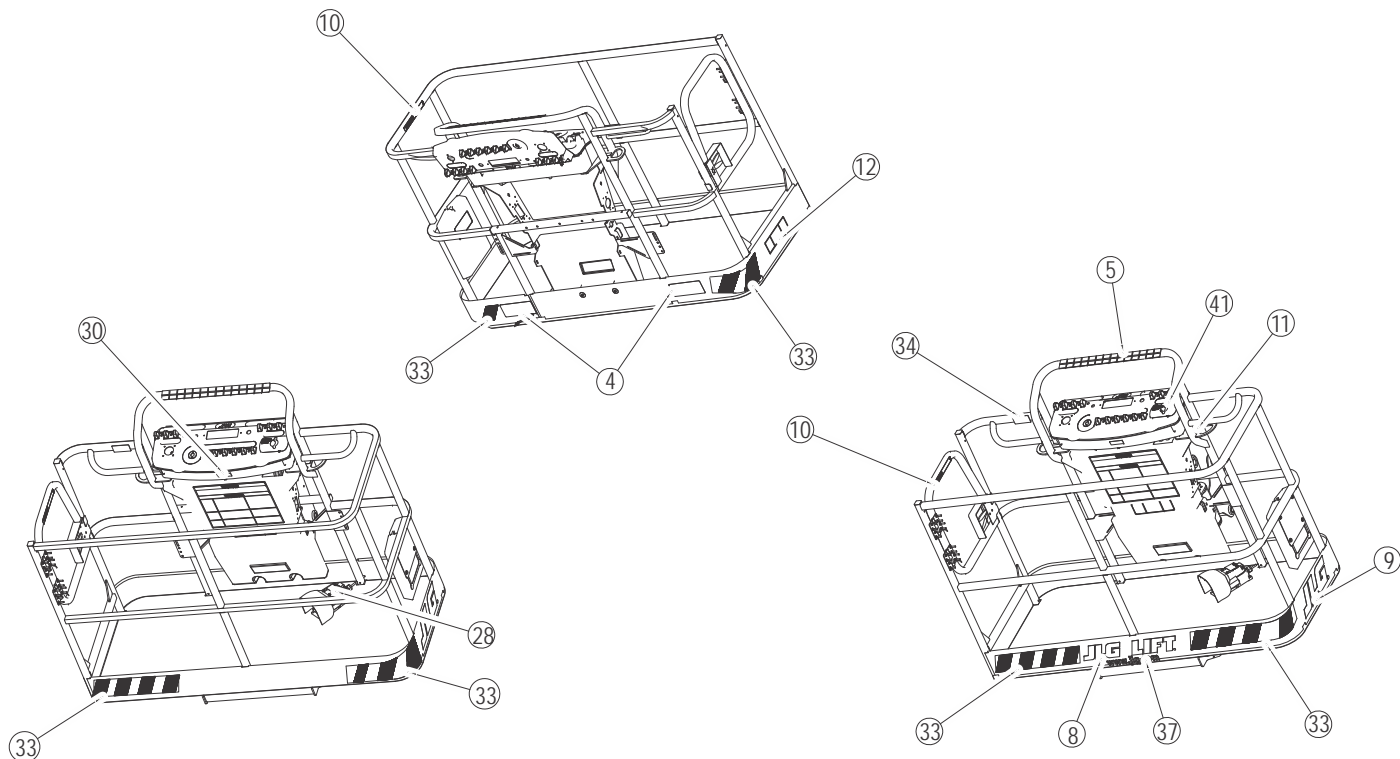
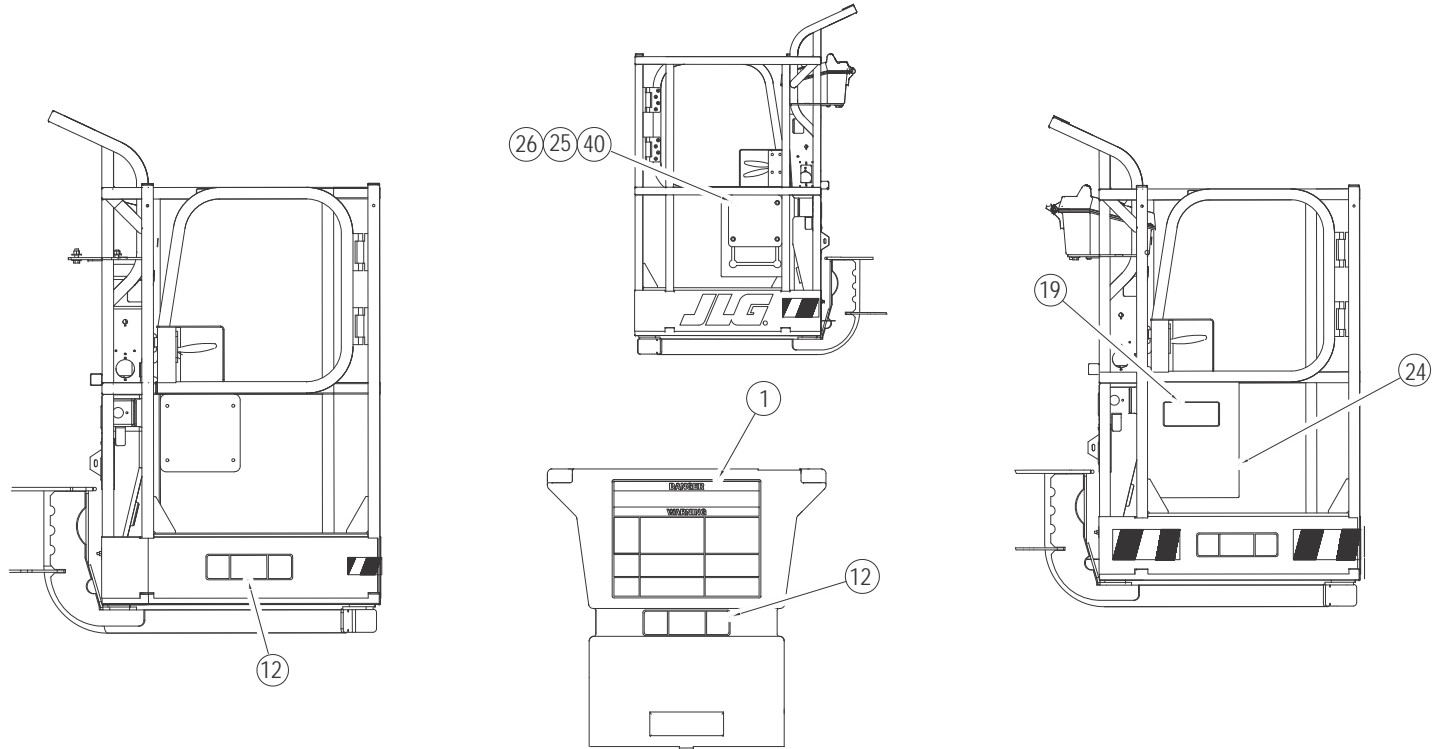

Figure 4-9. Decal Location Sheet 4 of 6



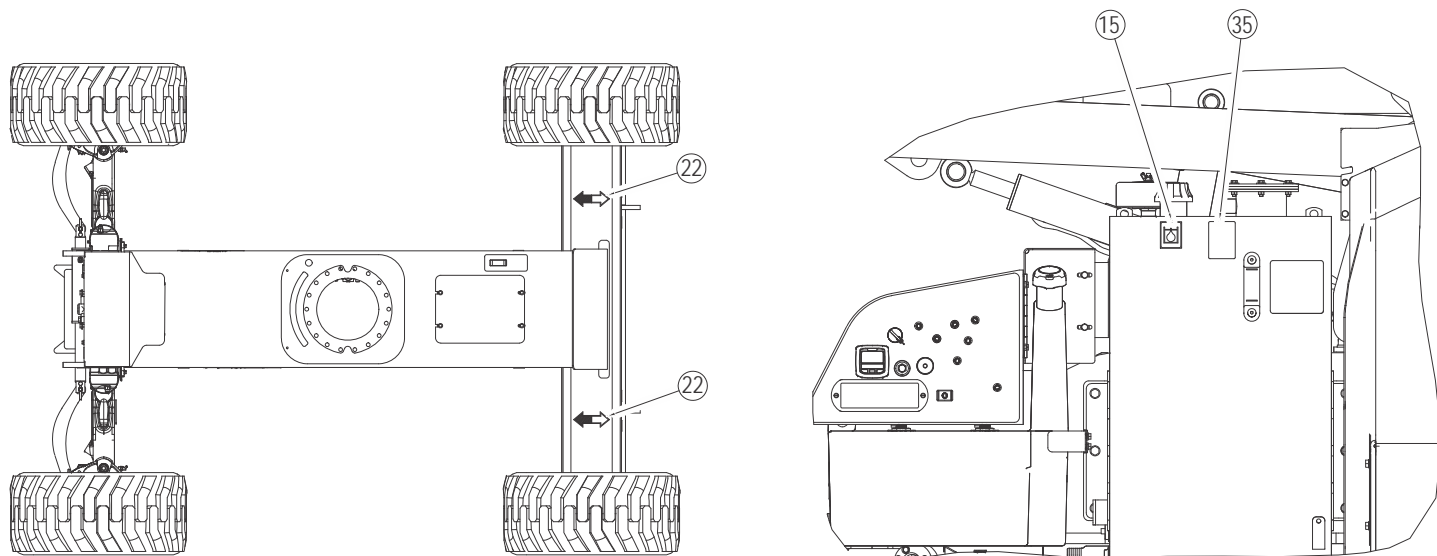

Figure 4-11. Decal Location Sheet 6 of 6

Table 4-1. Decal Legend - Language Markets

Item #	ANSI 1001162521-G	Australia 1001162522-E	Japan 1001162523-C	Korea 1001162524-C	French 1001162525-D	Chinese 1001162526-D	Portuguese 1001162527-F	CE 1001162528-G	Spanish 1001162529-F
1	1703797	1001162429	1703926	1703927	1703924	1703925	1703928	1001162429	1703923
2	1705336	1705822	1705344	1705345	1705347	1001116849	1705349	1705822	1705917
3	1703805	1705961	1703938	1703939	1703936	1703937	1703940	1705961	1703935
4	1703804	--	1703950	1703951	1703848	1703949	1703952	--	1703947
5	1001173262	--	--	--	1001173262	--	--	--	1001173262
6	1001174313	--	--	--	1001174313	--	--	--	1001174313
7	--	--	--	--	--	--	--	--	--
8	--	--	--	--	--	--	--	--	--
9	--	--	--	--	--	--	--	1702773	--
10	1702868	--	--	1705969	1704000	1705968	1704002	--	1704001
11	1704277	1704277	1704277	1704277	1704277	1704277	1704277	1704277	1704277
12	1001162416	1001190913	1001162418	1001162420	1001162422	1001162416	1001162426	1001190913	1001162415
13	--	--	--	--	--	--	--	--	--
14	1703953	1701518	1703944	1703945	1703942	1703953	1705903	1701518	1703941
15	1701504	1701504	1701504	1701504	1701504	1701504	1701504	1701504	1701504
16	1702631	1702631	1702631	1702631	1702631	1702631	1702631	1702631	1702631
17	1001131269	--	--	--	1001131269	--	--	--	--
18	--	--	--	--	--	--	--	--	--

SECTION 4 - MACHINE OPERATION

Table 4-1. Decal Legend - Language Markets

Item #	ANSI 1001162521-G	Australia 1001162522-E	Japan 1001162523-C	Korea 1001162524-C	French 1001162525-D	Chinese 1001162526-D	Portuguese 1001162527-F	CE 1001162528-G	Spanish 1001162529-F
19	1701509	1701509	1701509	1701509	1701509	1701509	1701509	1701509	1701509
20	1702300	1702300	1702300	1702300	1702300	1702300	1702300	1702300	1702300
21	1701500	1701500	1701500	1701500	1701500	1701500	1701500	1701500	1701500
22	1703687	1703687	1703687	1703687	1703687	1703687	1703687	1703687	1703687
23	3251243	--	--	--	3251243	--	3251243	--	3251243
24	--	--	--	--	--	--	--	--	--
25	--	--	--	--	--	--	--	--	--
26	--	--	--	--	--	--	--	--	--
27	--	--	--	--	--	--	--	--	--
28	--	--	1703980	1703981	1703984	1703982	1703985	1705828	1703983
29	--	--	--	--	--	--	--	--	--
30	1705514	--	--	--	1705514	--	--	--	--
31	--	--	--	--	--	--	--	--	--
32	--	--	--	--	--	--	--	--	--
33	--	--	--	--	--	--	--	--	--
34	--	--	--	--	--	--	--	--	--
35	1704412	1704412	1704412	1704412	1704412	1704412	1704412	1704412	1704412
36	1001172217	1001172217	1001172217	1001172217	1001172217	1001172217	1001172217	1001172217	1001172217

Table 4-1. Decal Legend - Language Markets

Item #	ANSI 1001162521-G	Australia 1001162522-E	Japan 1001162523-C	Korea 1001162524-C	French 1001162525-D	Chinese 1001162526-D	Portuguese 1001162527-F	CE 1001162528-G	Spanish 1001162529-F
37	1704885	1704885	1704885	1704885	1704885	1704885	1704885	1704885	1704885
38	--	--	--	--	--	--	--	--	--
39	--	--	--	--	--	--	--	--	--
40	--	--	--	--	--	--	--	--	--
41	1705351	--	1705426	1705427	1705351	1705430	1705905	--	1705910
42	1701499	1701499	1701499	1701499	1701499	1701499	1701499	1701499	1701499
43	3251813	--	--	--	3251813	--	3251813	1001204510	3251813
44	--	--	--	--	--	--	--	--	--
45	--	--	--	--	--	--	--	--	--
46	--	1001112551	--	--	--	--	--	1001189882	--
47	--	--	--	--	--	--	--	--	--
48	1701529	1701529	1701529	1701529	1701529	1701529	1701529	1701529	1701529
49	--	--	--	--	--	--	--	--	--
50	--	--	--	--	--	--	--	--	--
51	1001223055	--	1001224053	1001224048	1001223971	1001224050	1001224052	--	1001224049

SECTION 4 - MACHINE OPERATION

Table 4-2. Decal Legend - Kubota Engine-Powered Machines

Item #	ANSI ANSI Export China 1001218927-B	CSA French 1001218928-B
1	1703797	1703924
2	1705336	1705347
3	1703805	1703936
4	1703804	1703848
5	1001173262	1001173262
6	1001216408	1001216408
7	--	--
8	--	--
9	--	--
10	1702868	1704000
11	1704277	1704277
12	1001162416	1001162422
13	--	--
14	1703953	1703942
15	1701504	1701504
16	1702631	1702631
17	1001131269	1001131269

Table 4-2. Decal Legend - Kubota Engine-Powered Machines

Item #	ANSI ANSI Export China 1001218927-B	CSA French 1001218928-B
18	--	--
19	1701509	1701509
20	1702300	1702300
21	1701500	1701500
22	1703687	1703687
23	3251243	3251243
24	--	--
25	--	--
26	--	--
27	--	--
28	--	1703984
29	--	--
30	1705514	1705514
31	--	--
32	--	--
33	--	--
34	--	--

Table 4-2. Decal Legend - Kubota Engine-Powered Machines

Item #	ANSI ANSI Export China 1001218927-B	CSA French 1001218928-B
35	1704412	1704412
36	1001172217	1001172217
37	1704885	1704885
38	--	--
39	--	--
40	--	--
41	1705351	1705429
42	1701499	1701499
43	3251813	3251813
44	--	--
45	--	--
46	--	--
47	--	--
48	1701529	1701529
49	--	--
50	--	--
51	1001223055	1001223971

SECTION 5. EMERGENCY PROCEDURES

5.1 GENERAL

This section explains the steps to be taken in case of an emergency situation while operating.

5.2 INCIDENT NOTIFICATION

JLG Industries, Inc. must be notified immediately of any incident involving a JLG product. Even if no injury or property damage is evident, the factory should be contacted by telephone and provided with all necessary details.

- USA: 877-JLG-SAFE (554-7233)
- EUROPE: (32) 0 89 84 82 20
- AUSTRALIA: (61) 2 65 811111
- E-mail: ProductSafety@JLG.com

Failure to notify the manufacturer of an incident involving a JLG Industries product within 48 hours of such an occurrence may void any warranty consideration on that particular machine.

NOTICE

FOLLOWING ANY INCIDENT, THOROUGHLY INSPECT THE MACHINE AND TEST ALL FUNCTIONS FIRST FROM THE GROUND CONTROLS, THEN FROM THE PLATFORM CONTROLS. DO NOT LIFT ABOVE 3 M (10 FT.) UNTIL YOU ARE SURE THAT ALL DAMAGE HAS BEEN REPAIRED, IF REQUIRED, AND THAT ALL CONTROLS ARE OPERATING CORRECTLY.

5.3 EMERGENCY OPERATION

Operator Unable to Control Machine

IF THE PLATFORM OPERATOR IS PINNED, TRAPPED OR UNABLE TO OPERATE OR CONTROL MACHINE:

1. Other personnel should operate the machine from ground controls only as required.
2. Other qualified personnel on the platform may use the platform controls. DO NOT CONTINUE OPERATION IF CONTROLS DO NOT FUNCTION PROPERLY.
3. Cranes, forklift trucks or other equipment can be used to stabilize motion of the machine.

Platform or Boom Caught Overhead

If the platform or boom becomes jammed or snagged in overhead structures or equipment, do the following:

1. Shut off the machine.
2. Rescue all people in the platform before freeing the machine. Personnel must be out of the platform before operating any controls on the machine.
3. Use cranes, forklifts, or other equipment to stabilize motion of the machine to prevent a tip over as required.
4. From the ground controls, use the Auxiliary Power System (if equipped) to carefully free the platform or boom from the object.
5. Once clear, restart the machine and return the platform to a safe position.
6. Inspect the machine for damage. If the machine is damaged or does not operate properly, turn off the machine immediately. Report the problem to the proper maintenance personnel. Do not operate the machine until it is declared safe for operation.

5.4 MANUAL SWING OVERRIDE

The manual swing override is used to manually swing the boom and turntable assembly in the event of a total power failure when the platform is positioned over a structure or obstacle. To operate the manual swing override, proceed as follows:

1. Using a 7/8 inch socket and ratchet wrench, locate nut on swing worm gear on left side of machine.
2. Install wrench on nut and ratchet in the direction desired.

5.5 EMERGENCY TOWING PROCEDURES

Towing this machine is prohibited. However, provisions for moving the machine have been incorporated. The following procedures are to be used **ONLY** for emergency movement to a suitable maintenance area.

NOTICE

THE ALLOWABLE TOWING SPEED IS 1.9 MPH (3 KPH). THE MAXIMUM ALLOWABLE TOWING DISTANCE IS 0.6 MILES (1 KM).

1. Chock wheels securely.
2. Engage the mechanical release on both drive hubs by loosening, completely reversing, and tightening the two bolts on each hub.
3. Connect suitable equipment, remove chocks, and move machine.

After moving machine, complete the following procedure:

1. Position machine on a firm level surface.
2. Chock wheels securely.
3. Disengage the mechanical release on both drive hubs by loosening, completely reversing, and tightening the two bolts on each hub.
4. Remove chocks from wheels as desired.

5.6 MACHINE SAFETY SYSTEM OVERRIDE (MSSO)(CE ONLY)

The Machine Safety System Override (MSSO) is only to be used to retrieve an operator that is pinned, trapped, or unable to operate the machine. The MSSO will override function controls that are locked out from the platform and ground consoles. An example of this would be in the case of Load Sense System activation.



NOTE: *If the MSSO functionality is used, the fault indicator will flash and a fault code is set in the JLG Control System which must be reset by a qualified JLG Service Technician.*

NOTE: *No functional checks of the MSSO system are necessary. The JLG Control system will set a Diagnostic Trouble Code if the control switch is faulty.*

To operate the MSSO:

1. From the ground control console, place the Platform/ Ground Select switch in the Ground position.
2. Pull out the Power/Emergency Stop control.
3. Start the engine or MSSO will function through the Auxiliary Power system.
4. Press and hold the MSSO switch and the control switch for the desired function.

SECTION 6. ACCESSORIES

Table 6-1. Available Accessories

Accessory	Market					
	ANSI (USA Only)	ANSI	CSA	CE	AUS	China
Fall Arrest Platform (30" x 60")	√		√			
Pipe Racks	√	√	√	√	√	√
SkyGlazier™	√		√		√	
SkyPower™	√	√	√	√	√	√
SkyWelder™	√	√	√			√
Soft Touch™	√	√				√

SECTION 6 - ACCESSORIES

Table 6-2. Options/Accessories Relationship Table

ACCESSORY	REQUIRED ITEM	COMPATIBLE WITH (Note 1)	INCOMPATIBLE WITH	INTERCHANGABLE WITH (Note 2)
Pipe Racks		SkyPower™	Platform MMR**, Platform MTR*, Soft Touch	SkyGlazier™, SkyWelder™
SkyGlazier™		SkyPower™	4' Platform, Pipe Racks, Platform MTR*, Soft Touch	SkyWelder™
SkyPower™		SkyGlazier™, SkyWelder™		
SkyWelder™	SkyPower™		4' Platform, Pipe Racks, Platform MTR*, Soft Touch	SkyGlazier™
Soft Touch		SkyPower™	Pipe Racks, SkyGlazier™, SkyWelder™	
Note 1: Any non-"Sky" accessory not listed under "INCOMPATIBLE WITH" is assumed to be compatible.				
Note 2: Can be used on same unit but not simultaneously.				
* Platform MTR = Platform Mesh to Top Rail; ** Platform MMR = Platform Mesh to Mid Rail				

4150459 M

6.1 FALL ARREST PLATFORM

NOTE: See the JLG External Fall Arrest System manual (PN 3128935) for more information.

The external fall arrest system is designed to provide a lanyard attach point while allowing the operator to access areas outside the platform. Exit/enter the platform through the gate area only. The system is designed for use by one person.

Personnel must use fall protection at all times. A full body harness is required with lanyard not to exceed 6 ft (1.8 m) in length, that limits the maximum arrest force to 900 lbs (408 kg) for the trans-faster type and 1350 lbs (612 kg) for the shuttle type fall arrest system.

Safety Precautions

⚠ WARNING

DO NOT OPERATE ANY MACHINE FUNCTIONS WHILE OUTSIDE THE PLATFORM. USE CAUTION WHEN ENTERING/EXITING THE PLATFORM AT ELEVATION.

6.2 PIPE RACKS

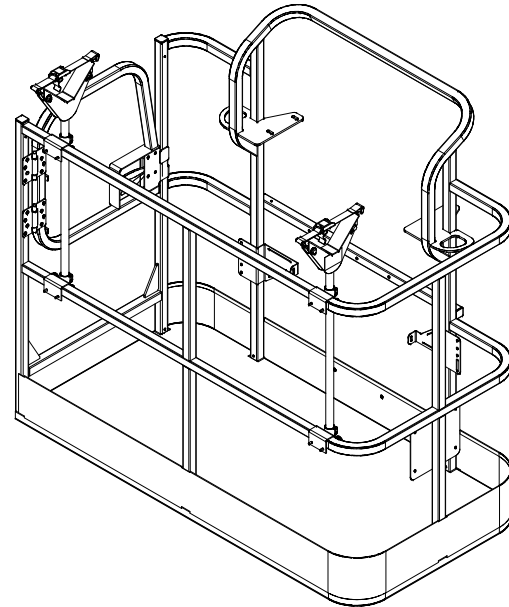

Pipe Racks provide a way to store pipe or conduit inside the platform in order to prevent rail damage and optimize platform utility. This accessory consists of two racks with adjustable straps to secure the load in place.

Capacity Specifications (Australia Only)

Max. Capacity in Racks	Max. Platform Capacity (With Max. Weight in Racks)
80 kg	184 kg
Max. Length of Material in Racks: 6.0 m Min. Length of Material in Racks: 2.4 m	

Safety Precautions

WARNING

REDUCE PLATFORM CAPACITY BY 100 LBS (45.5 KG) WHEN INSTALLED.

WARNING

WEIGHT IN RACKS PLUS WEIGHT IN PLATFORM MUST NOT EXCEED RATED CAPACITY.

NOTICE

THE MAXIMUM LOAD IN THE RACKS IS 180 LBS (80 KG) EVENLY DISTRIBUTED BETWEEN THE TWO RACKS.

NOTICE

THE MAXIMUM LENGTH OF MATERIAL IN RACKS IS 20 FT (6.1 M).

- Ensure no personnel are beneath the platform.
- Do not exit platform over rails or stand on rails.
- Do not drive machine without material secured
- Return racks to the stowed position when not in use.
- Use this option only on approved models.

Preparation and Inspection

- Ensure racks are secured to the platform rails.
- Replace torn or frayed tie-down straps.

Operation

1. To prepare racks for loading, remove locking pins, rotate each rack 90 degrees from stowed to working position, then secure with locking pins.
2. Loosen and remove tie-down straps. Place material on racks with weight evenly distributed between both racks.
3. Route the tie-down straps at each end across loaded material and tighten.
4. To remove material, loosen and remove tie-down straps, then carefully remove material from racks.

NOTE: *Reinstall tie-down straps across any remaining material before continuing machine operations.*

6.3 SKYGLAZIER™

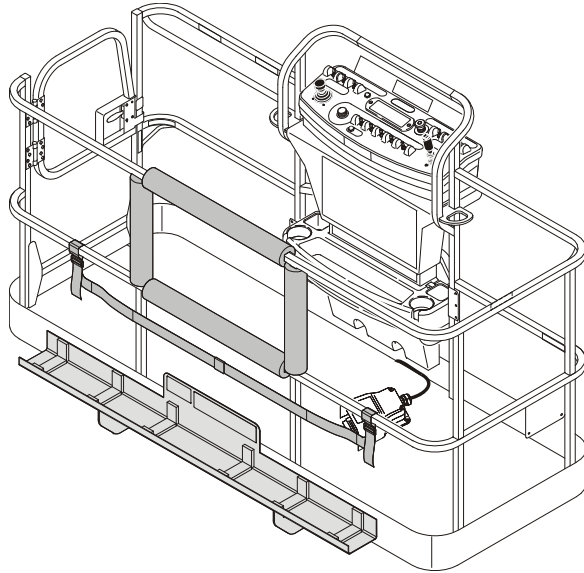

SkyGlazier™ allows glaziers to position panels efficiently. The glazier package consists of a tray that attaches the bottom of the platform. The panel rests on the tray and against top-rail of the platform, which is padded to prevent damage. SkyGlazier™ includes a strap to secure the panel to the platform rail.

Capacity Specifications

Capacity Zone *	Max. Tray Capacity	Max. Platform Capacity (With Max. Weight in Tray)
500 lbs (227 kg)	150 lbs (68 kg)	250 lbs (113 kg)
550 lbs (250 kg)	150 lbs (68 kg)	250 lbs (113 kg)
600 lbs (272 kg)	150 lbs (68 kg)	250 lbs (113 kg)
750 lbs (340 kg)	150 lbs (68 kg)	440 lbs (200 kg)
1000 lbs (454 kg)	250 lbs (113 kg)	500 lbs (227 kg)
* Refer to the capacity decals installed on the machine for capacity zone information.		
Required Platform Type: Side-Entry		
Max. Dimensions of Panel: 32 sq ft (3 sq m)		

Safety Precautions

WARNING

ENSURE PANEL IS SECURED WITH STRAP.

WARNING

DO NOT OVERLOAD TRAY OR PLATFORM. TOTAL MACHINE CAPACITY IS REDUCED WHEN TRAY IS INSTALLED.

WARNING

WITH SKYGLAZIER™ INSTALLED, THE ORIGINAL PLATFORM CAPACITY RATINGS ARE REDUCED AS SPECIFIED IN THE SPECIFICATIONS TABLE ABOVE. DO NOT EXCEED THE NEW PLATFORM CAPACITY RATING. REFER TO CAPACITY DECAL LOCATED ON TRAY.

WARNING

AN INCREASE OF THE AREA EXPOSED TO THE WIND WILL DECREASE STABILITY. LIMIT PANEL AREA TO 32 SQ FT (3 SQ M).

- Ensure no personnel are beneath platform.
- Do not exit platform over rails or stand on rails.
- Remove tray when not in use.
- Use this option only on approved models.

Preparation and Inspection

- Check for cracked welds and damage to tray.
- Ensure tray is properly secured to platform.
- Ensure strap is not torn or frayed.

Operation

1. Load SkyGlazier™ tray with panel.
2. Route the adjustable strap around the panel and tighten until secure.
3. Position panel to its desired location.

6.4 SKYPOWER™

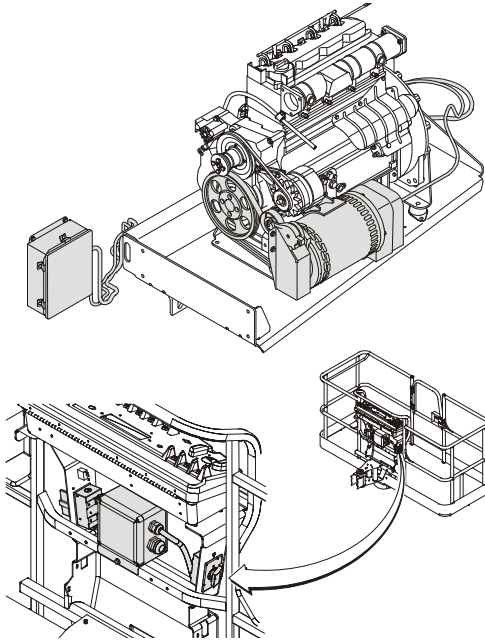

The SkyPower™ system supplies AC power to the platform through an AC receptacle to run tools, lights, cutting, and welding equipment.

All power regulation components are located in a watertight box connected by cable to the generator. The generator supplies power when running at the specified speed with the power switch on (switch is located on platform). A three-pole, 30 Amp circuit breaker protects the generator from overload.

Generator Output

ANSI Specifications:

- 3-phase: 240 V, 60 Hz, 7.5 kW
- 1-phase: 240 V/120 V, 60 Hz, 6 kW

CE Specifications:

- 3-phase: 240 V, 7.5 kW, 18.3 A, 1.0-pf
- 1-phase: 240 V, 6.0 kW, 26 A, 1.0-pf
- 1-phase: 120 V, 6.0 kW, 50 A, 1.0-pf

Peak:

- 3-phase: 8.5 kW
- 1-phase: 6.0 kW

Accessory Ratings

- 3000 rpm (50 Hz)
- 3600 rpm (60 Hz)

Safety Precautions

⚠ WARNING

DO NOT OVERLOAD PLATFORM.

- Ensure no personnel are beneath platform.
- This factory-installed option is available only on specified models.
- Keep lanyard attached at all times.
- Do not use electrical tools in water.
- Use correct voltage for tool being used.
- Do not overload circuit.

Preparation and Inspection

- Ensure generator is secure.
- Check condition of belt and wiring.

Operation

Start the engine, then turn on the generator.

See the Miller Generator Technical Manual (PN 3121677) for more information.

6.5 SKYWELDER™

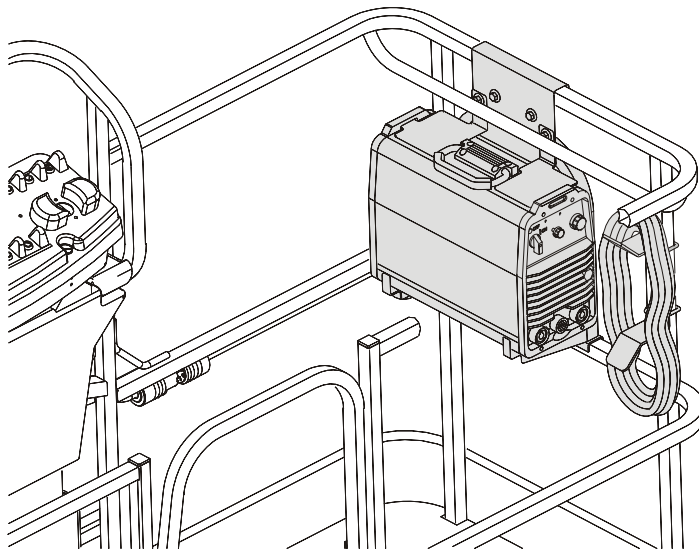

SkyWelder™ is capable of TIG and Stick welding, producing 200 Amps at 100% duty cycle or 250 Amps at 50% duty cycle. It receives power from the SkyPower™ system.

Accessory Ratings

Welding Mode	Input Power	Rated Output	Welding Amperage Range	Maximum Open Circuit Voltage	Amps Input At Rated Load Output (50/60 Hz)				
					230 V	460 V	575 V	kVa	kW
Stick (SMAW) TIG (GTAW)	3-phase	280 Amp at 31.2 V, 35% Duty Cycle	5-250 A	79VDC	32	17	13	15.7	10
		200 Amp at 28 V, 100% Duty Cycle			20	11	8	10.3	6.4
	1-phase	200 Amp at 28 V, 50% Duty Cycle	5-200 A	79VDC	35	-----	-----	9.8	6.5
		150 Amp at 28 V, 100% Duty Cycle			34	-----	-----	6.9	4.4

Generator Output

Engine Speed of 1800 rpm +/- 10%.

ANSI Specifications:

- 3-phase: 240 V, 60 Hz, 7.5 kW
- 1-phase: 240 V/120 V, 60 Hz, 6 kW

Welding Accessories

- 12 ft welding leads with clamp and stinger (stored in the platform)
- Fire extinguisher

Safety Precautions

⚠ WARNING

DO NOT OVERLOAD PLATFORM.

⚠ WARNING

DE-RATE THE PLATFORM BY 70 LBS (32 KG) WHEN WELDER IS IN THE PLATFORM.

- Check for cracked welds and damage to welder supports.
- Check for proper and secure installation of welder and bracket.
- Ensure no personnel are beneath platform.
- Do not exit platform over rails or stand on rails.
- Use this option only on approved models.
- Keep lanyard attached at all times.
- Ensure correct polarity of leads.
- Wear proper welding apparel.

- Use correct rod size and current settings.
- Do not use electrical cords without ground.
- Do not use electrical tools in water.
- Do not weld to the platform.
- Do not ground through the platform.
- Do not use a high frequency arc starter with TIG welder.

Preparation and Inspection

- Connect ground clamp to metal being welded.
- Ensure there is a good ground connection and observe proper polarity.

Operation

Start the engine, turn on the generator, then turn on the welder.

See the Miller Welder Owner's Manual (PN 3128957) for more information.

6.6 SOFT TOUCH

A padding kit is mounted to the platform rails and a frame suspended below the platform. Limit switches deactivate platform functions when the padded framework contacts an adjacent structure. A button on the platform console allows override of the system.

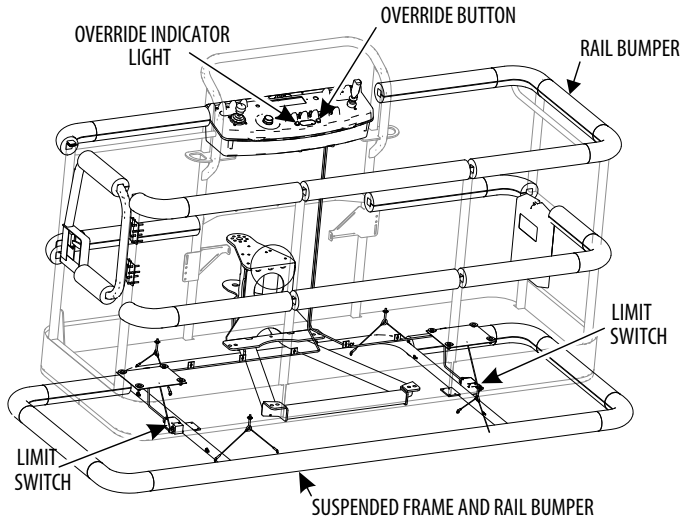

SECTION 7. GENERAL SPECIFICATIONS & OPERATOR MAINTENANCE

7.1 INTRODUCTION

This section of the manual provides additional necessary information to the operator for proper operation and maintenance of this machine.

The maintenance portion of this section is intended as information to assist the machine operator to perform daily maintenance tasks only, and does not replace the more thorough Preventive Maintenance and Inspection Schedule included in the Service and Maintenance Manual.

Other Publications Available:

Service and Maintenance Manual3121659
 Illustrated Parts Manual3121660

7.2 OPERATING SPECIFICATIONS AND PERFORMANCE DATA

Operating Specifications

Table 7-1. Operating Specifications

Capacity: Unrestricted:	550lbs. (249.5 kg)
Maximum Travel Grade, stowed Position (Gradeability)	45%
Maximum Travel Grade, stowed Position (Side Slope)	5°
Drive Speed - Stowed	4.25 mph (6.8 kph)
Gross Machine Weight - Approximate	13,250 lbs. (6010 kg)
Maximum Ground Bearing Pressure	65 psi (4.6 kg/cm ²)
Max. Tire Load	7200 lbs. (3266 kg)
System Voltage	12VDC
Maximum Main Relief Hyd. Pressure	4060 psi (280 Bar)
Average Fuel Consumption	0.85 gph (3.2 lph)

SECTION 7 - GENERAL SPECIFICATIONS & OPERATOR MAINTENANCE

Dimensional Data

Table 7-2. Dimensional Data

Turning Radius (Inside)	6' 9" (2.06 m)
Turning Radius (Outside)	15' 8" (4.78 m)
Machine Height (stowed)	89.3" (2269 mm)
Machine Length (stowed)	258.9" (6576 mm)
Up and Over Platform Height	24' (7.3 m)
Horizontal Reach	25' (7.62 m)
Machine Width	92.6" (2353 m)
Wheel Base	93.0" (2362 mm)
Platform Height	45' 9" (13.72 m)
Ground Clearance	16.4" (417 mm)

Capacities

Table 7-3. Capacities

Hydraulic System	38 gal. (143.8 L)
Hydraulic Oil Tank (to Full Level)	31.7 Gal. (119.9 L)
Drive Hub	24 oz. (0.7 L)
Drive Brake	27 oz. (0.8 L)
Engine Coolant	
Deutz 2.9L	2.9 gal. (11.3 L)
GM 3.0L	2.4 gal. (9.1 L)
Kubota	2.25 gal. (8.5 L)

Tires

Table 7-4. Tires

Size	Type	Pressure	Weight
33/1550x16.5	Pneumatic	90 psi (6 Bar)	135 lbs. (61 kg)
	Foam-Filled	N/A	395 lbs. (179 kg)
12x16.5	Foam-Filled	N/A	328 lbs. (149 kg)
33/16LLx16.1	Pneumatic	40 psi (3 Bar)	155 lbs. (70 kg)
315/55D20	Foam-Filled	N/A	286 lbs. (130 kg)
	Solid	N/A	286 lbs. (130 kg)
33x12-20	Solid	N/A	285 lbs. (129 kg)

Engine Data

Table 7-5. Deutz D2011L03

Fuel	Diesel
No. of Cylinders	3
Bore	3.7 in (94 mm)
Stroke	4.4 in (112 mm)
Displacement	142 cu. in (2331 cm ³)
Oil Capacity	
crankcase	6.3 qt (6L)
cooler	3.7 qt (3.5L)
total capacity	10 qt (9.5L)
Low RPM	1200
Mid RPM	
Tower Lift, Upper Lift, Tele	
Swing, Basket Level, Basket	1800
Rotate, Jib Lift	1500
High RPM	2800

SECTION 7 - GENERAL SPECIFICATIONS & OPERATOR MAINTENANCE

Table 7-6. Deutz D2.9L4

Type	Liquid Cooled
Number of Cylinders	4
Bore	3.6 in (92 mm)
Stroke	4.3 in (110 mm)
Total Displacement	178 cu. in (2925 cm ³)
Firing Order	1-3-4-2
Output	49 hp (36.5 kW)
Oil Capacity	2.4 gal (8.9 L)
Coolant Capacity (System)	3.2 gal (12.1 L)
Average Fuel Consumption	1.2 gph (4.1 Lph)
Min. Low Engine RPM	1200
Mid Engine RPM	1800
Max. High Engine RPM	2500

Table 7-7. GM 3.0L

Fuel	Gasoline or Gasoline/LP Gas
No. of Cylinders	4
BHP	
Gasoline	82 hp @ 3000 rpm
LP	75 hp @ 3000 rpm
Bore	4.0 in (101.6 mm)
Stroke	3.6 in (91.44 mm)
Displacement	181 cu.in(3.0L, 2966 cc)
Oil Capacity w/filter	4.5 qt (4.25 L)
Minimum Oil Pressure	
at idle	6 psi (0.4 bar) @ 1000 rpm
Hot	18 psi (1.2 bar) @ 2000 rpm
Compression Ratio	9.2:1
Firing Order	1-3-4-2
Max. RPM	2800

Table 7-8. Kubota WG 2503

Fuel	Gasoline or Gasoline/LP Gas			
BHP				
Gasoline	45.5 kW @2700 rpm			
LP	46 Kw @2700 rpm			
Bore	3.46 in (88 mm)			
Stroke	4.03 in (102.4 mm)			
Displacement	153 cu.in(2.5L)			
Oil Capacity w/filter	2.5 gal (9.5L)			
Coolant Capacity (engine only)	1.4gal (5.4L)			
Max. RPM	2700			
Fuel Consumption - Gasoline	In Drive	2.35 Gal/Hr	8.92 L/Hr	--
	@ Idle	0.48 Gal/Hr	1.83 L/Hr	--
Fuel Consumption - LP	In Drive	2.56 Gal/Hr	9.72 L/Hr	5.64 kg/Hr
	@ Idle	0.62 Gal/Hr	2.36 L/Hr	1.37 kg/Hr

Hydraulic Oil

Table 7-9. Hydraulic Oil

Hydraulic System Operating Temperature Range	S.A.E. Viscosity Grade
+0° to +180° F (-18° to +83° C)	10W
+0° to +210° F (-18° to +99° C)	10W-20, 10W30
+50° to +210° F (+10° to +99° C)	20W-20

NOTE: Hydraulic oils require anti-wear qualities at least API Service Classification GL-3, and sufficient chemical stability for mobile hydraulic system service.

NOTE: Machines may be equipped with Mobil EAL biodegradable and non-toxic hydraulic oil. This is a fully synthetic hydraulic oil that possesses the same anti-wear and rust protection characteristics as mineral oils, but will not adversely affect the ground water or the environment when spilled or leaked in small amounts.

SECTION 7 - GENERAL SPECIFICATIONS & OPERATOR MAINTENANCE

NOTE: *Aside from JLG recommendations, it is not advisable to mix oils of different brands or types, as they may not contain the same required additives or be of comparable viscosities. If use of hydraulic oil other than Mobil 424 is desired, contact JLG Industries for proper recommendations.*

Table 7-10. Mobilfluid 424 Specs

SAE Grade	10W30
Gravity, API	29.0
Density, Lb/Gal. 60°F	7.35
Pour Point, Max	-46°F (-43°C)
Flash Point, Min.	442°F (228°C)
Viscosity	
Brookfield, cP at -18°C	2700
at 40°C	55 cSt
at 100°C	9.3 cSt
Viscosity Index	152

Table 7-11. DTE 10 Excel 15 Specs

ISO Viscosity Grade	#15
Pour Point, Max	-65°F (-54°C)
Flash Point, Min.	360°F (182°C)
Viscosity	
at 40°C	15.8 cSt
at 100°C	4.1 cSt
at 100°F	15.8 cSt
at 210°F	4.1 cSt
Viscosity Index	168

SECTION 7 - GENERAL SPECIFICATIONS & OPERATOR MAINTENANCE

Table 7-12. Quintolubric 888-46

Density	0.91 @ 15°C (59°F)
Pour Point	<-20°C (<-4°F)
Flash Point	275°C (527°F)
Fire Point	325°C (617°F)
Autoignition Temperature	450°C (842°F)
Viscosity	
at 0°C (32°F)	360 cSt
at 20°C (68°F)	102 cSt
at 40°C (104°F)	46 cSt
at 100°C (212°F)	10 cSt
Viscosity Index	220

Table 7-13. Mobil EAL 224H Specs

Type	Synthetic Biodegradable
ISO Viscosity Grade	32/46
Specific Gravity	.922
Pour Point, Max	-25°F (-32°C)
Flash Point, Min.	428°F (220°C)
Operating Temp.	0 to 180°F (-17 to 162°C)
Weight	7.64 lb. per gal. (0.9 kg per liter)
Viscosity	
at 40°C	37 cSt
at 100°C	8.4 cSt
Viscosity Index	213
NOTE: Must be stored above 32°F (14°C)	

SECTION 7 - GENERAL SPECIFICATIONS & OPERATOR MAINTENANCE

Table 7-14. Exxon Univis HVI 26 Specs

Specific Gravity	32.1
Pour Point	-76°F (-60°C)
Flash Point	217°F (103°C)
Viscosity	
at 40°C	25.8 cSt
at 100°C	9.3 cSt
Viscosity Index	376
NOTE: <i>Mobil/Exxon recommends that this oil be checked on a yearly basis for viscosity.</i>	

Major Component Weights



DO NOT REPLACE ITEMS CRITICAL TO STABILITY WITH ITEMS OF DIFFERENT WEIGHT OR SPECIFICATION (FOR EXAMPLE: BATTERIES, FILLED TIRES, PLATFORM) DO NOT MODIFY UNIT IN ANY WAY TO AFFECT STABILITY.

Table 7-15. Critical Stability Weights

Components	LBS.	KG.
Counterweight	1875 ± 75	850.5 ± 34
Tire and Wheel - 20x9 Pneumatic	130	59
Tire and Wheel - 20x9 Foam-Filled	220	99.8
Tire and Wheel - 18x7	230	104.3
Platform & Console - 30x60	242.5	110
Platform & Console - 30x48	216	98
Battery	66	30

SECTION 7 - GENERAL SPECIFICATIONS & OPERATOR MAINTENANCE

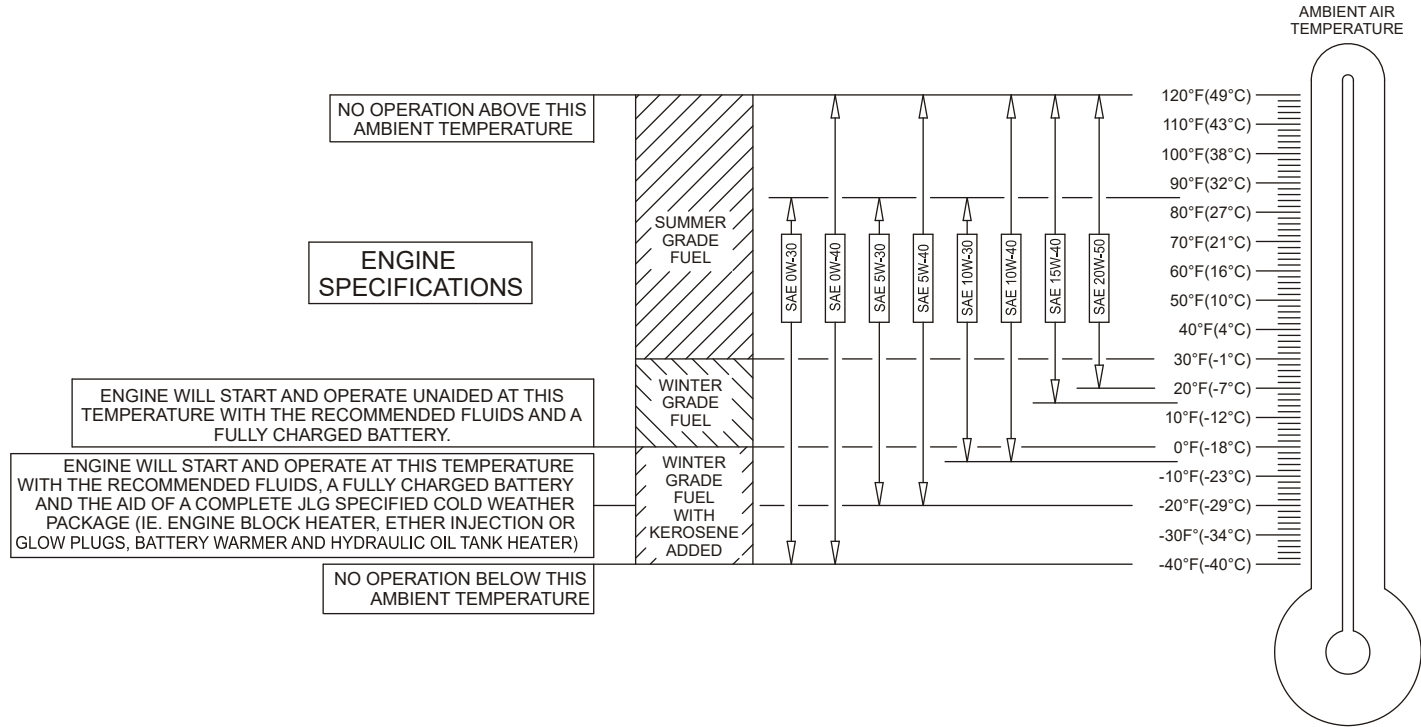

Figure 7-1. Engine Operating Temperature Specifications - Deutz 2.3L - Sheet 1 of 2

SECTION 7 - GENERAL SPECIFICATIONS & OPERATOR MAINTENANCE

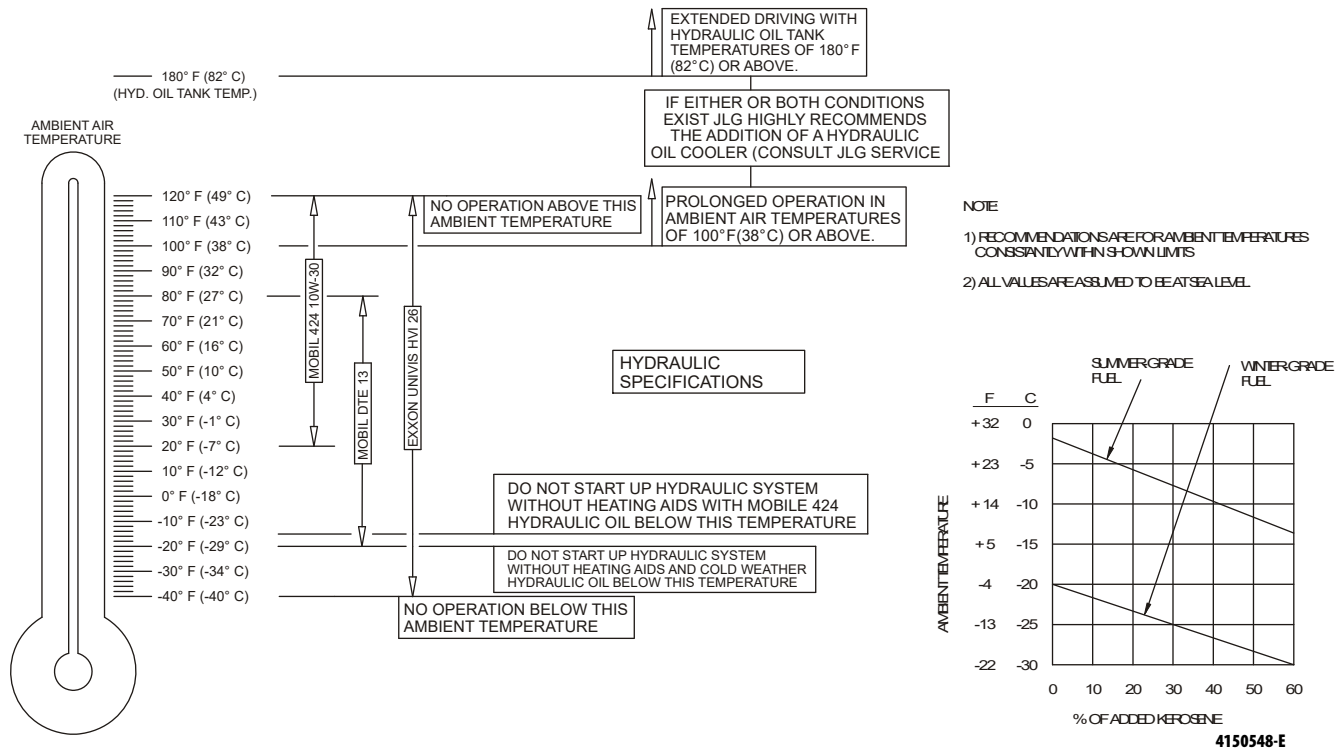

Figure 7-2. Engine Operating Temperature Specifications - Deutz 2.3L - Sheet 2 of 2

SECTION 7 - GENERAL SPECIFICATIONS & OPERATOR MAINTENANCE

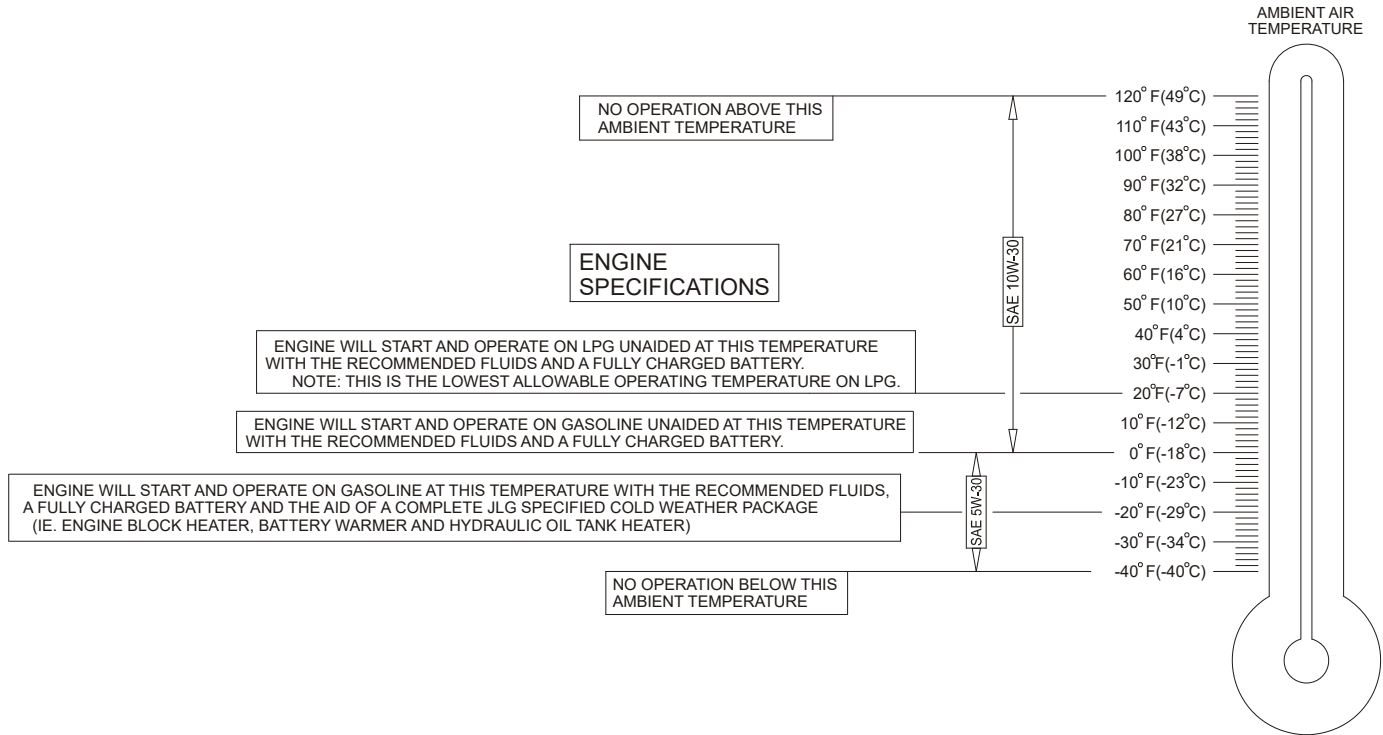
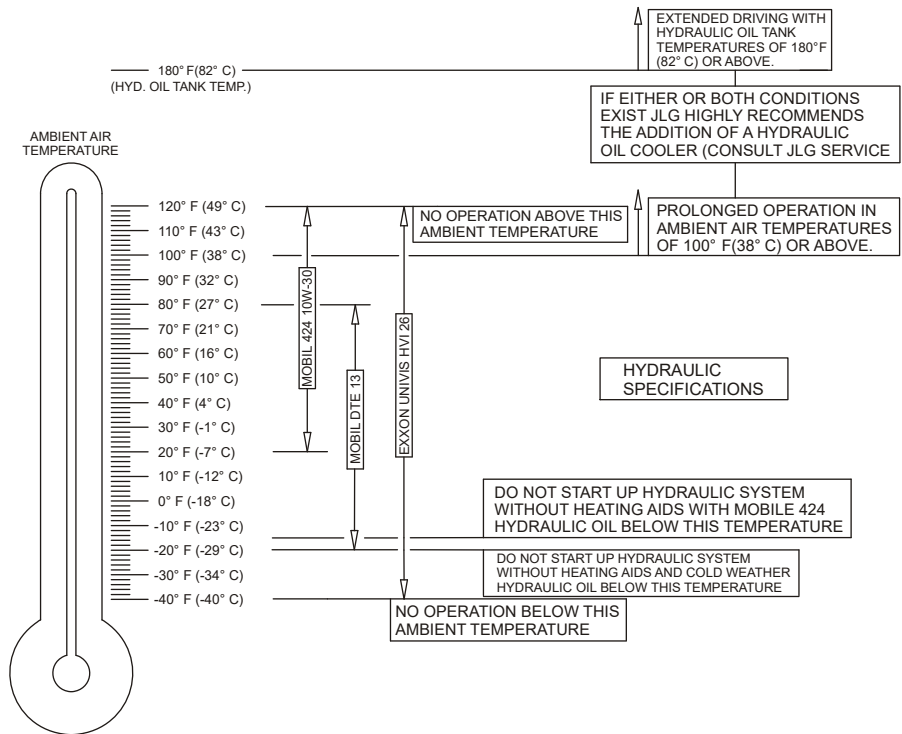

Figure 7-3. Engine Operating Temperature Specifications - GM - Sheet 1 of 2

SECTION 7 - GENERAL SPECIFICATIONS & OPERATOR MAINTENANCE



NOTE:

- 1) RECOMMENDATIONS ARE FOR AMBIENT TEMPERATURES CONSISTENTLY WITHIN SHOWN LIMITS
- 2) ALL VALUES ARE ASSUMED TO BE AT SEA LEVEL.

Figure 7-4. Engine Operating Temperature Specifications - GM - Sheet 2 of 2

4150548-E

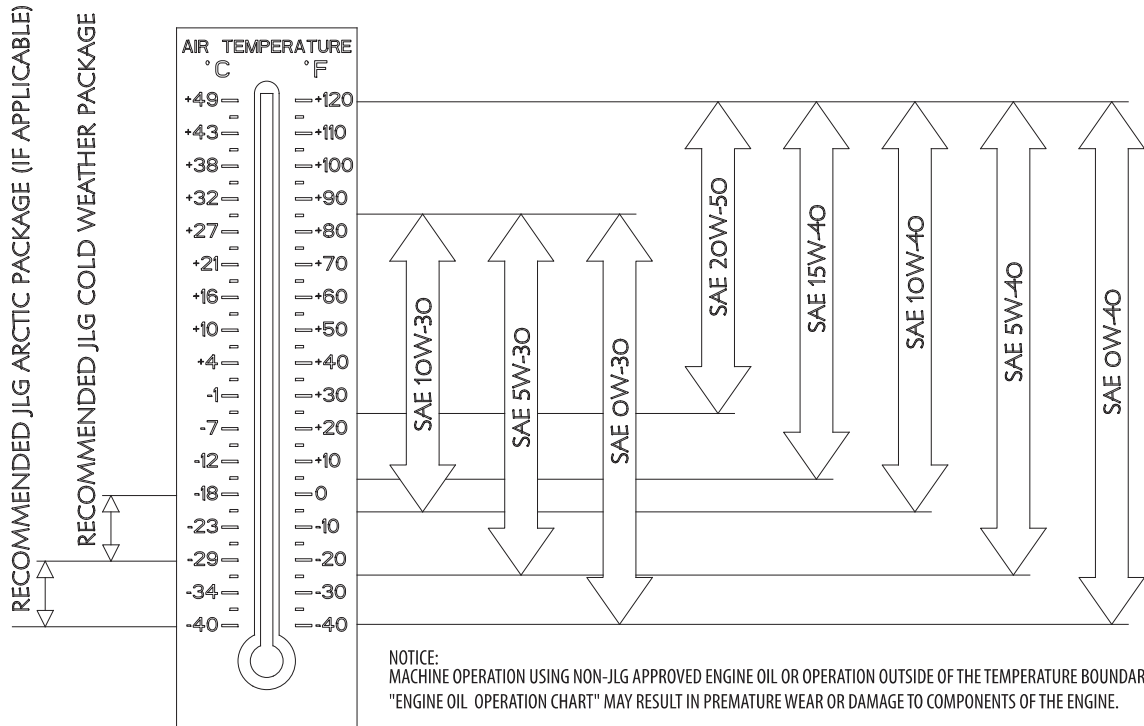

1001159163-A

Figure 7-5. Engine Operating Temperature Specifications - Deutz 2.9L

SECTION 7 - GENERAL SPECIFICATIONS & OPERATOR MAINTENANCE

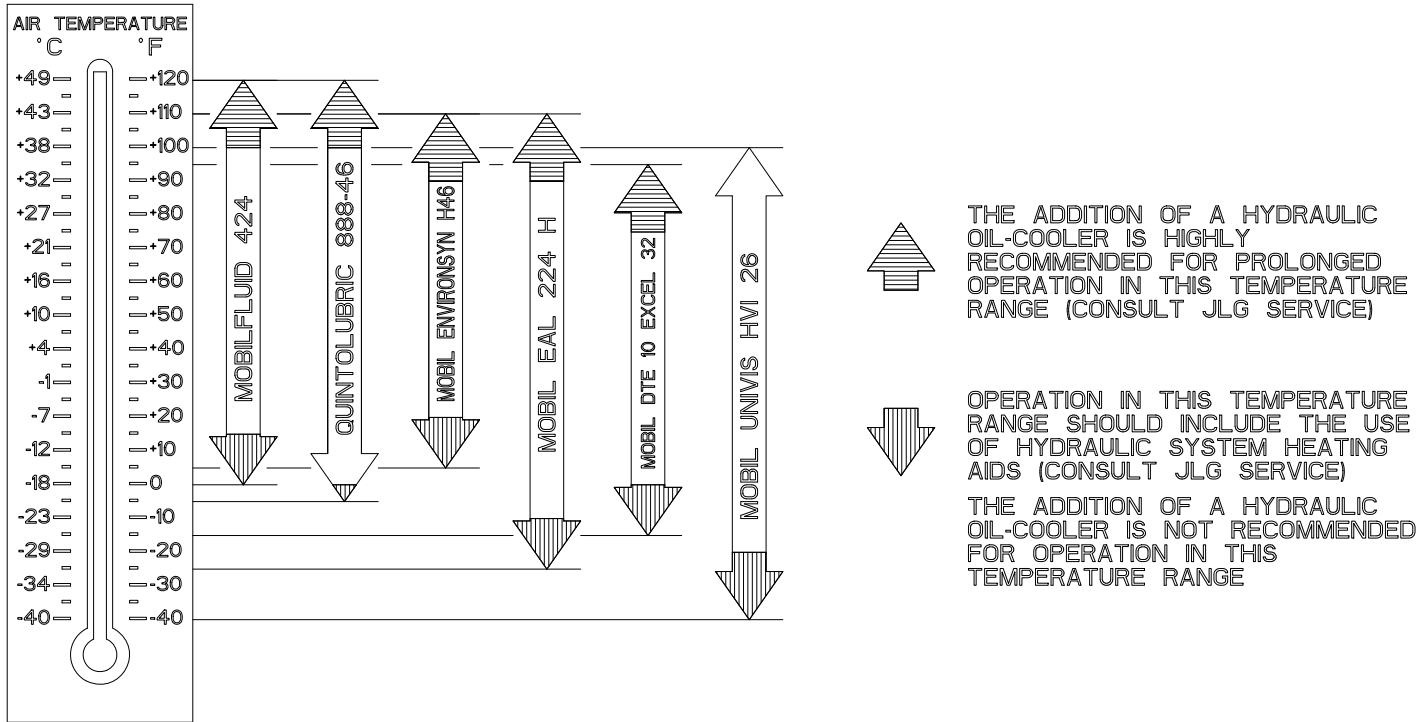

Figure 7-6. Hydraulic Oil Operation Chart - Sheet 1 of 2

1001206353 A

SECTION 7 - GENERAL SPECIFICATIONS & OPERATOR MAINTENANCE

Fluid	Properties		Base				Classification		
	Viscosity @ 40° C (Cst, Typical)	Visc Index	Mineral Oils	Vegetable Oils	Synthetic	Synthetic Polyol Esters	Readily Biodegradable*	Virtually Non-toxic**	Fire Resistant***
Mobilfluid 424	55	145	X						
Mobil DTE 10 Excel 32	32	141	X						
UNIVIS HVI 26	26	376	X						
Mobil EAL 224 H	36	212		X			X	X	
Mobil EnviroSyn H 46	49	145			X		X	X	
Quintolubric 888-46	50	185				X	X	X	X

- * Readily biodegradable classification indicates one of the following:
CO2 Conversion>60% per EPA 560/6-82-003
CO2 Conversion>80% per CEC-L-33-A-93
- ** Virtually Non-toxic classification indicates an LC50>5000 ppm per OECD 203
- *** Fire Resistant classification indicates Factory Mutual Research Corp. (FMRC) Approval

NOTICE:
MACHINE OPERATION USING NON-JLG APPROVED HYDRAULIC FLUIDS OR OPERATION OUTSIDE OF THE TEMPERATURE BOUNDARIES OUTLINED IN THE "HYDRAULIC FLUID OPERATION CHART" MAY RESULT IN PREMATURE WEAR OR DAMAGE TO COMPONENTS OF THE HYDRAULIC SYSTEM.

Figure 7-7. Hydraulic Oil Operation Chart - Sheet 2 of 2

SECTION 7 - GENERAL SPECIFICATIONS & OPERATOR MAINTENANCE

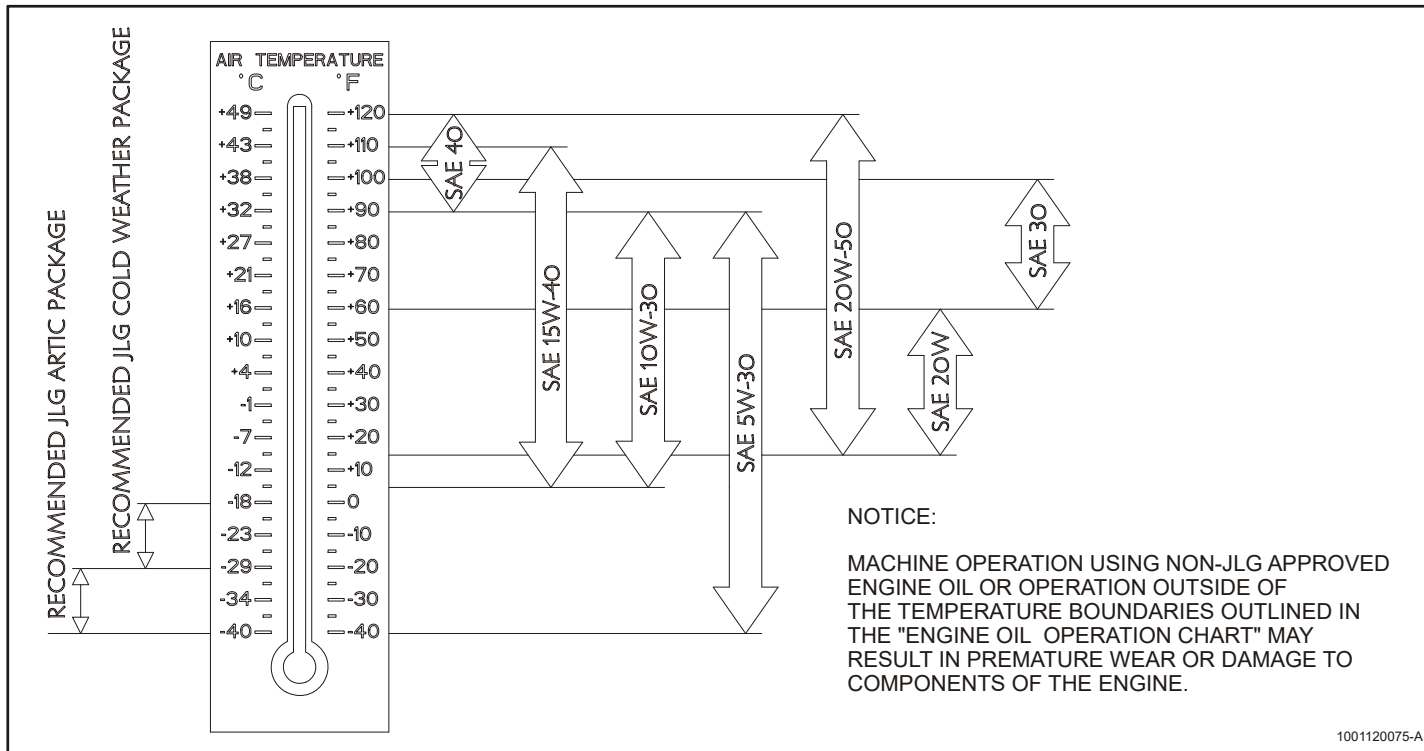

Figure 7-8. Engine Oil Operation Chart - Kubota

SECTION 7 - GENERAL SPECIFICATIONS & OPERATOR MAINTENANCE

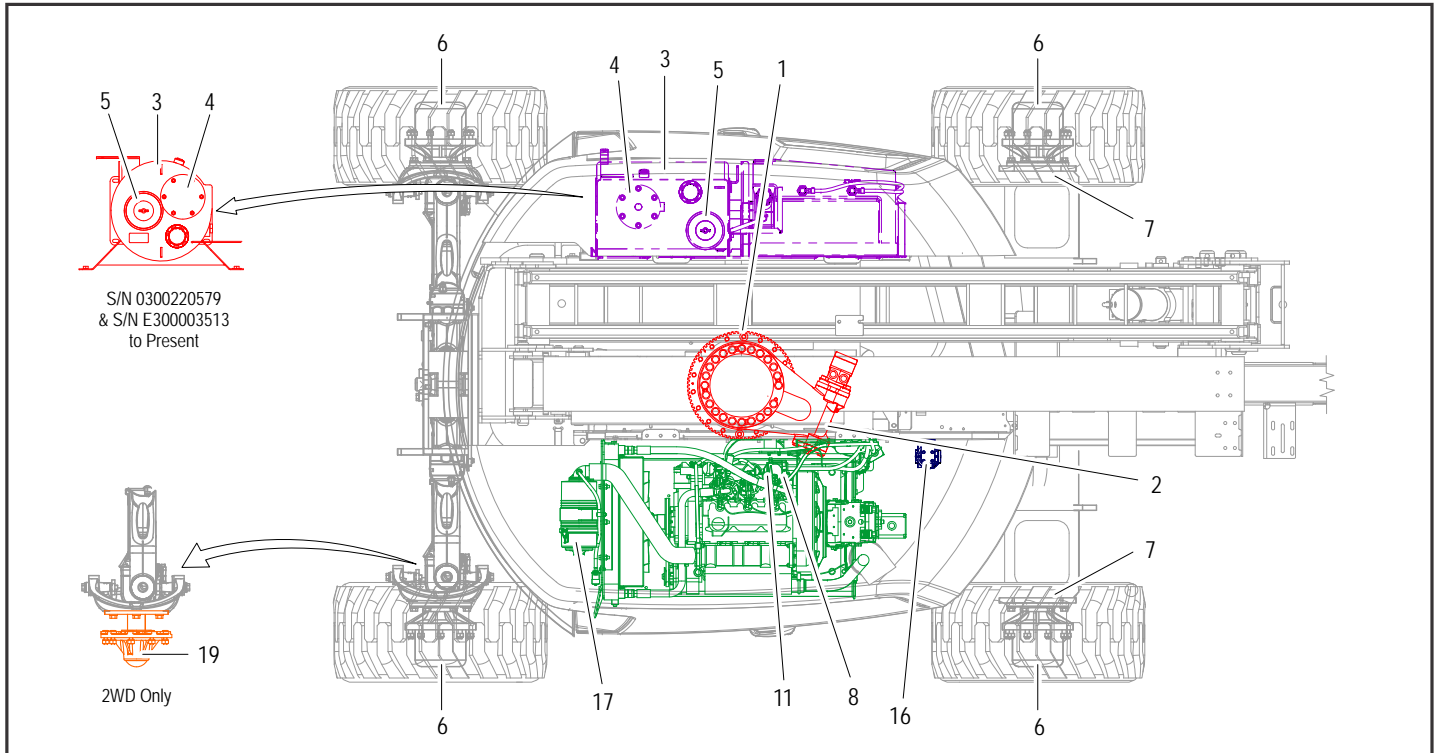

Figure 7-9. Operator Maintenance and Lubrication Diagram - Deutz 2.3L Engine

SECTION 7 - GENERAL SPECIFICATIONS & OPERATOR MAINTENANCE

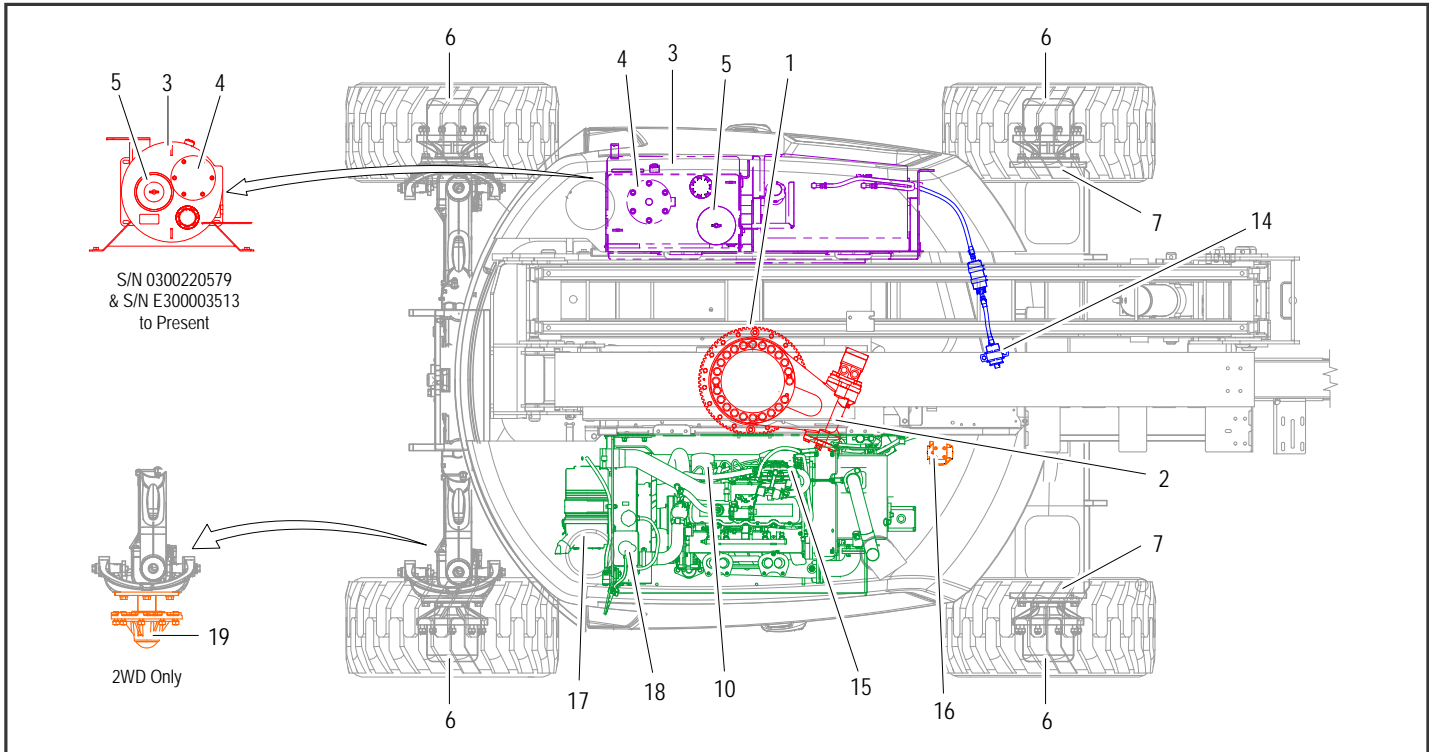

Figure 7-10. Operator Maintenance and Lubrication Diagram - GM Engine

SECTION 7 - GENERAL SPECIFICATIONS & OPERATOR MAINTENANCE

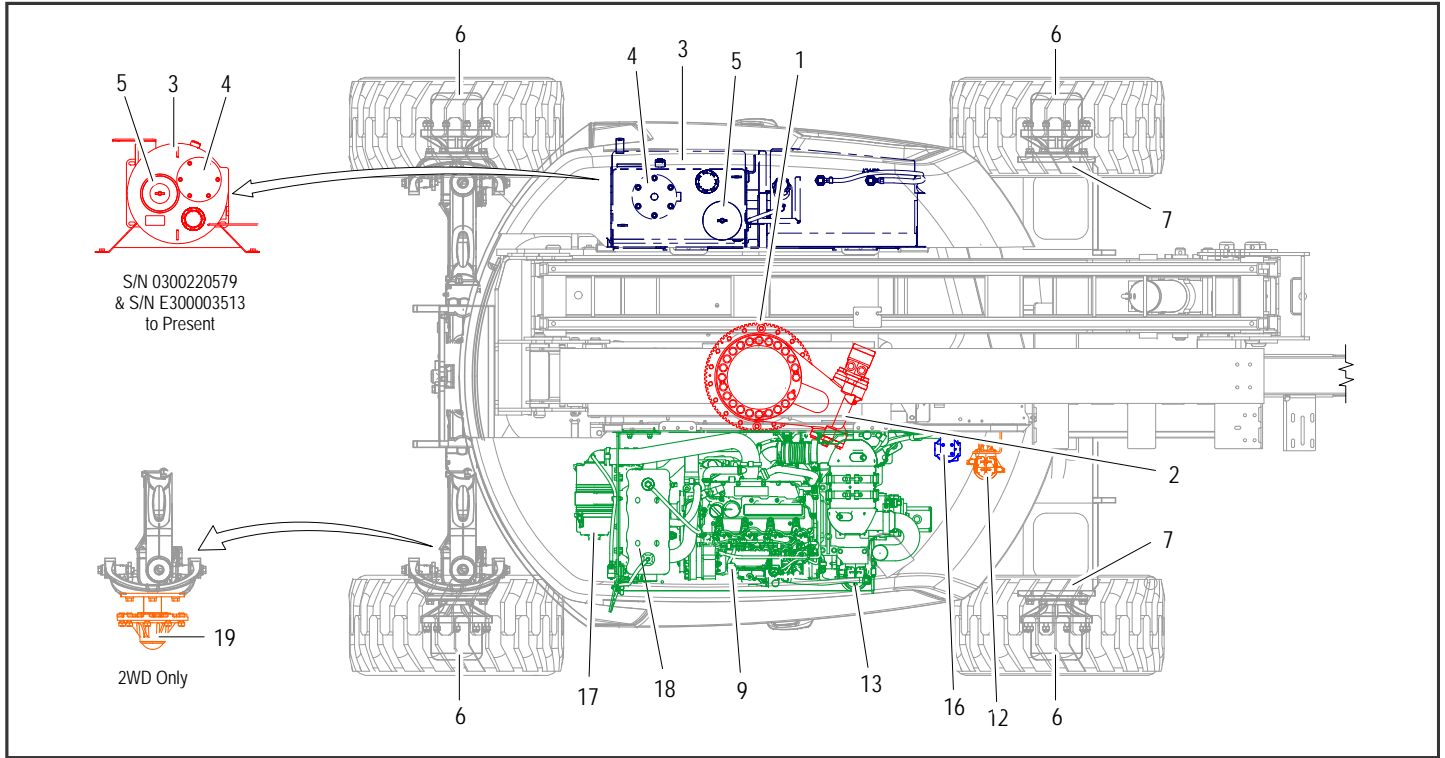

Figure 7-11. Operator Maintenance and Lubrication Diagram - Deutz 2.9L Engine

SECTION 7 - GENERAL SPECIFICATIONS & OPERATOR MAINTENANCE

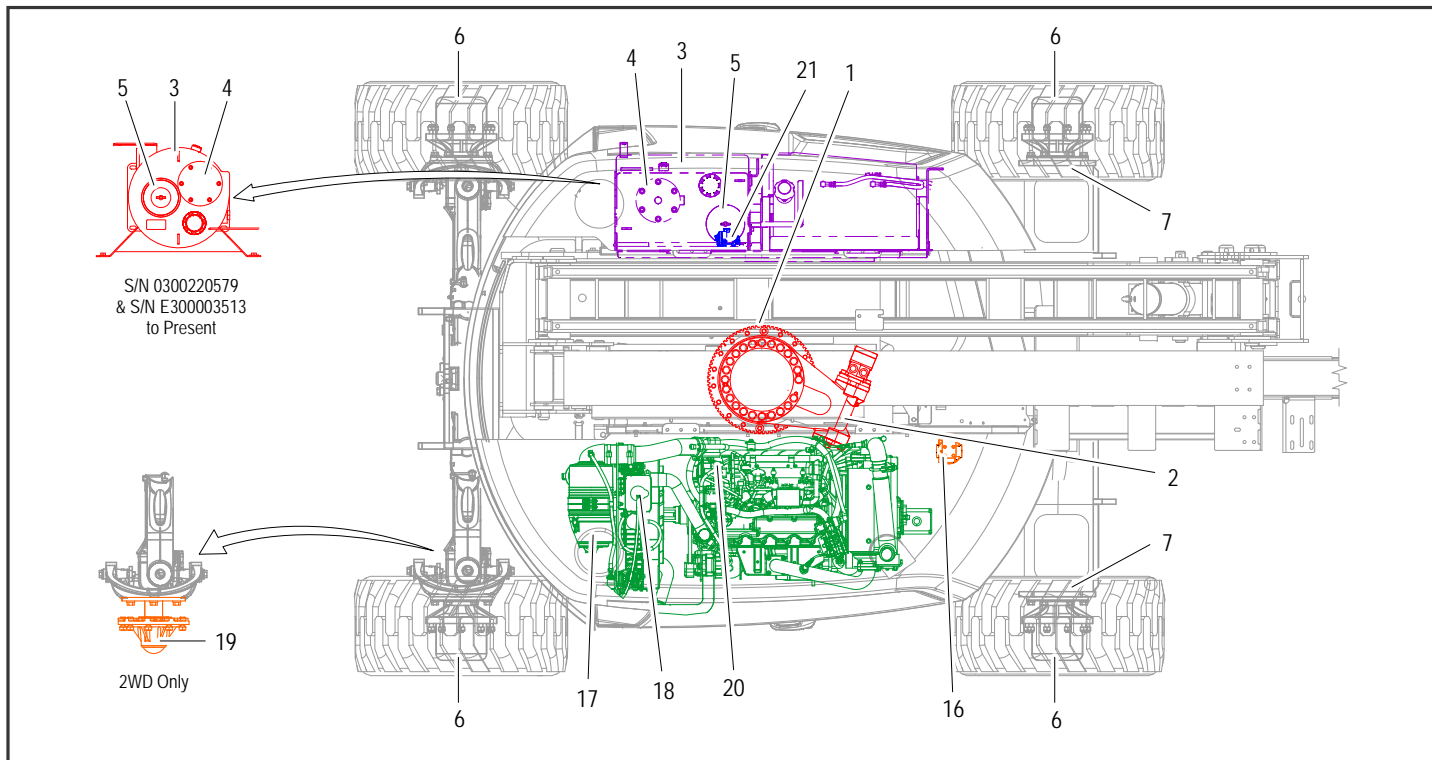

Figure 7-12. Operator Maintenance and Lubrication Diagram - Kubota Engine

7.3 OPERATOR MAINTENANCE

NOTE: The following numbers correspond to those in Figure 7-9., Operator Maintenance and Lubrication Diagram - Deutz 2.3L Engine.

Table 7-16. Lubrication Specifications.

KEY	SPECIFICATIONS
BG*	Bearing Grease (JLG Part No. 3020029) Mobilith SHC 460.
HO	Hydraulic Oil. API service classification GL-4, e.g. Mobilfluid 424.
EPGL	Extreme Pressure Gear Lube (oil) meeting API Service Classification GL-5 or Mil-Spec Mil-L-2105.
MPG	Multipurpose Grease having a minimum dripping point of 350°F (177°C). Excellent water resistance and adhesive qualities, and being of extreme pressure type. (Timken OK 40 pounds minimum.)
EO	Engine (crankcase). Gas (5W30) - API SN, -Arctic ACEA A1/BI, A5/B5 - API SM, SL, SJ, EC, CF, CD - ILSAC GF-4. Diesel (15W40, 5W30 Arctic) - API CJ-4.
*MPG may be substituted for these lubricants, if necessary, but service intervals will be reduced.	

NOTICE

LUBRICATION INTERVALS ARE BASED ON MACHINE OPERATION UNDER NORMAL CONDITIONS. FOR MACHINES USED IN MULTI-SHIFT OPERATIONS AND/OR EXPOSED TO HOSTILE ENVIRONMENTS OR CONDITIONS, LUBRICATION FREQUENCIES MUST BE INCREASED ACCORDINGLY.

1. Swing Bearing

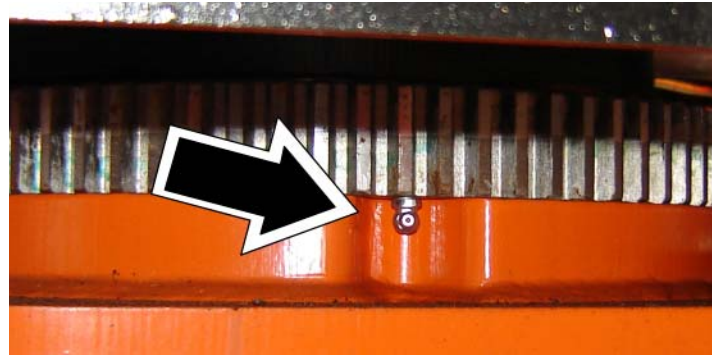

Lube Point(s) - Fitting

Capacity - A/R

Lube - BG

Interval - Every 3 months or 150 hrs of operation

Comments - Apply grease and rotate in 90 degree intervals until bearing is completely lubricated

SECTION 7 - GENERAL SPECIFICATIONS & OPERATOR MAINTENANCE

2. Swing Bearing/Worm Gear Teeth

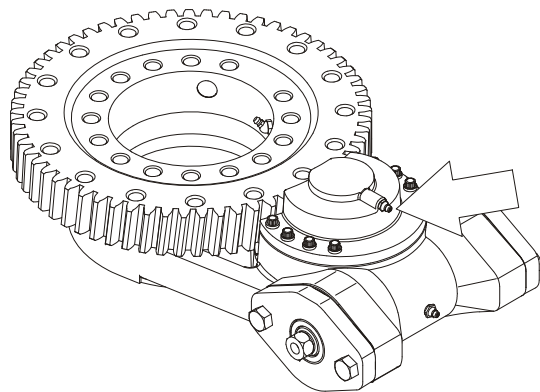

Lube Point(s) - Grease Fitting
Capacity - A/R
Lube - Lubriplate 930-AAA
Interval - A/R

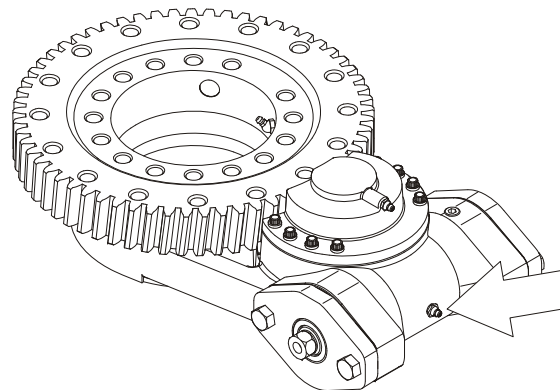

Lube Point(s) - Grease Fitting
Capacity - A/R
Lube - Mobil SHC 007
Interval - A/R

⚠ CAUTION

DO NOT OVERGREASE BEARINGS. OVERGREASING BEARINGS WILL RESULT IN DAMAGE TO OUTER SEAL IN HOUSING.

SECTION 7 - GENERAL SPECIFICATIONS & OPERATOR MAINTENANCE

3. Hydraulic Tank - Prior to S/N 0300220579 & S/N E300003513



Lube Point(s) - Fill Cap

Capacity - 36 Gal. (136.3 L), 31.7 Gal. (119.9 L) to Full Level; 28.8 Gal (109.0 L) to Low Level

Lube - HO

Interval - Check Level daily; Change every 2 years or 1200 hours of operation.

Comments - On new machines, those recently overhauled, or after changing hydraulic oil, operate all systems a minimum of two complete cycles and recheck oil level in reservoir.

Hydraulic Tank - S/N 0300220579 & S/N E300003513 to Present

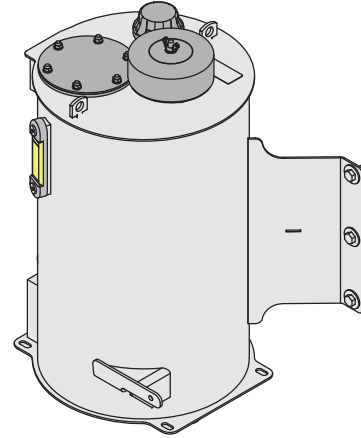

Lube Point(s) - Fill Cap

Capacity - 15 Gal. (57 L) to Full Level

Lube - HO

Interval - Check Level daily; Change every 2 years or 1200 hours of operation.

Comments - On new machines, those recently overhauled, or after changing hydraulic oil, operate all systems a minimum of two complete cycles and recheck oil level in reservoir.

SECTION 7 - GENERAL SPECIFICATIONS & OPERATOR MAINTENANCE

4. Hydraulic Return Filter

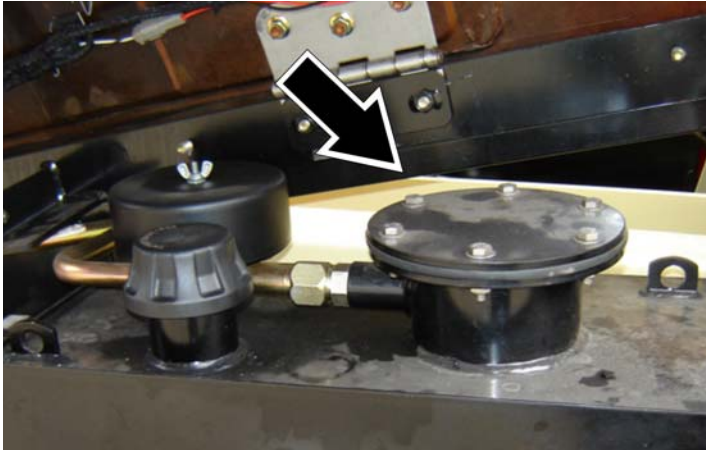

Lube Point(s) - Replaceable Element

Interval - Change after first 50 hours and every 6 months or 300 hours thereafter.

5. Hydraulic Tank Breather



Interval - Change after first 50 hrs. and every 6 months or 300 hrs. thereafter.

Comments - Remove wing nut and cover to replace. Under certain conditions, it may be necessary to replace on a more frequent basis.

6. Wheel Drive Hub

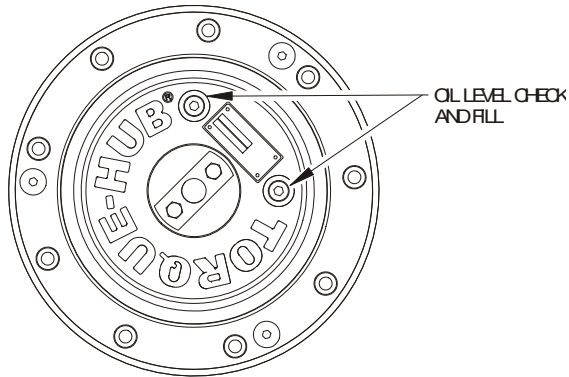

Lube Point(s) - Level/Fill Plug
Capacity - 24 oz. (0.8 L)(1/2 Full)
Lube - EPGL

Interval - Check level every 3 months or 150 hrs of operation;
change every 2 years or 1200 hours of operation

7. Drive Brake

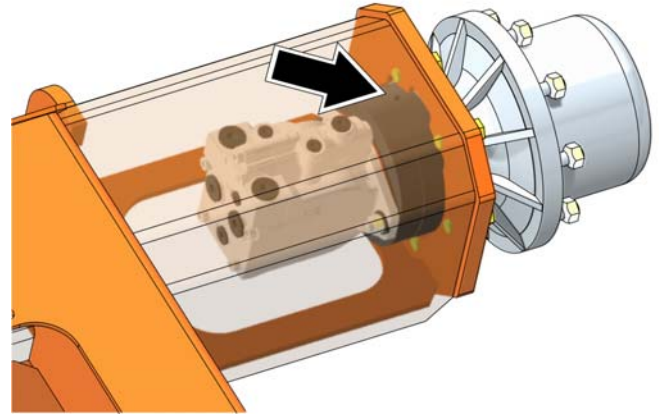

Lube Point(s) - Fill Plug
Capacity - 2.7 oz. (89 mL)
Lube - DTE-10 Excel 32
Interval - Change as necessary

SECTION 7 - GENERAL SPECIFICATIONS & OPERATOR MAINTENANCE

8. Oil Change with Filter - Deutz 2.3 L3

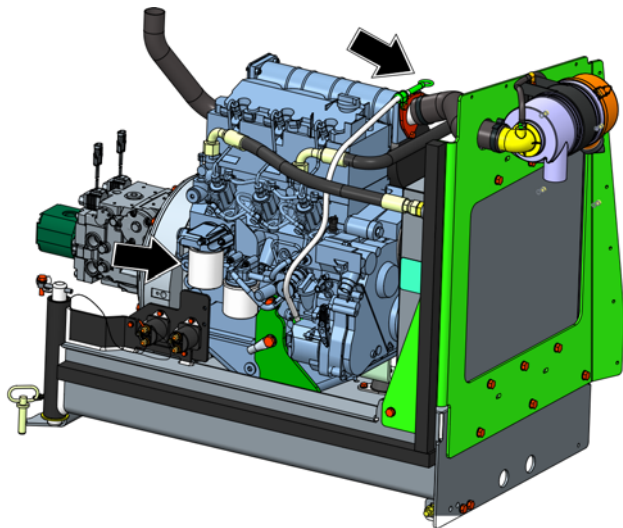

Lube Point(s) - Fill Cap/Spin-on Element
Capacity - 10 Quarts (9.5 L) w/Filter
Lube - EO

Interval - Check level daily; change every 500 hours or six months, whichever comes first. Adjust final oil level by mark on dipstick.

9. Oil Change w/Filter - Deutz 2.9 L4

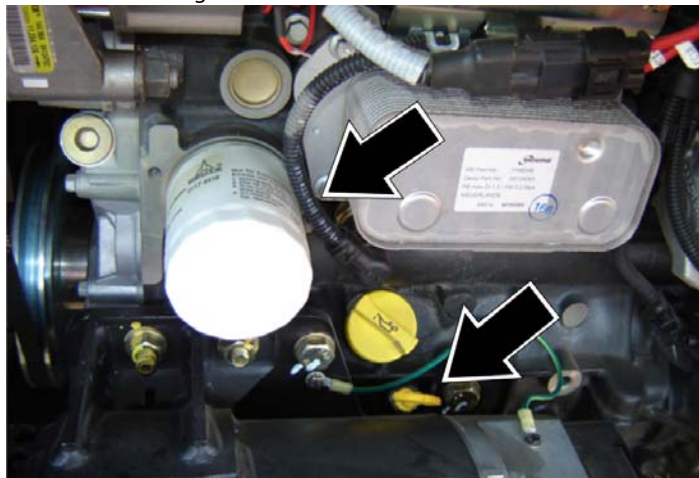

Lube Point(s) - Fill Cap/Spin-on Element
Capacity - 2.4 gal (8.9 L)
Lube - EO

Interval - Every Year or 600 hours of operation
Comments - Check level daily/Change in accordance with engine manual

10. Oil Change w/Filter - GM

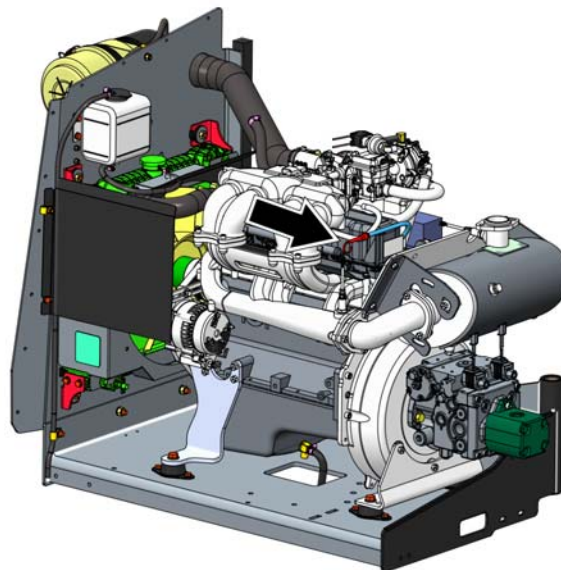
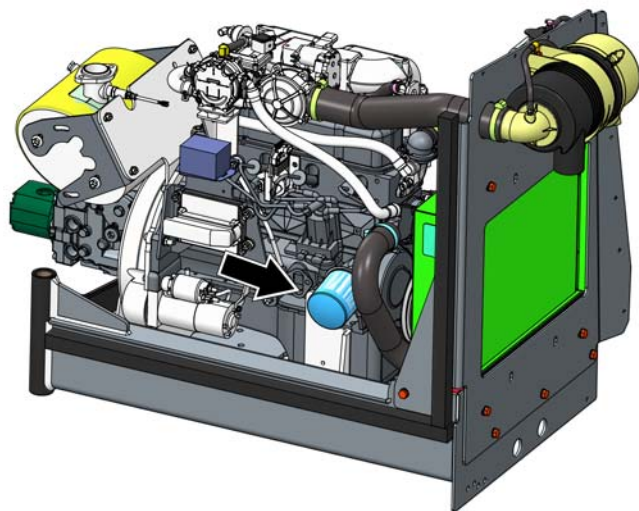

Lube Point(s) - Fill Cap/Spin-on Element

Capacity - 4.5 qt (4.25 L) w/filter

Lube - EO

Interval - 3 Months or 150 hours of operation

Comments - Check level daily/Change in accordance with engine manual

SECTION 7 - GENERAL SPECIFICATIONS & OPERATOR MAINTENANCE

11. Fuel Filter/Water Separator - Deutz 2.3 L3

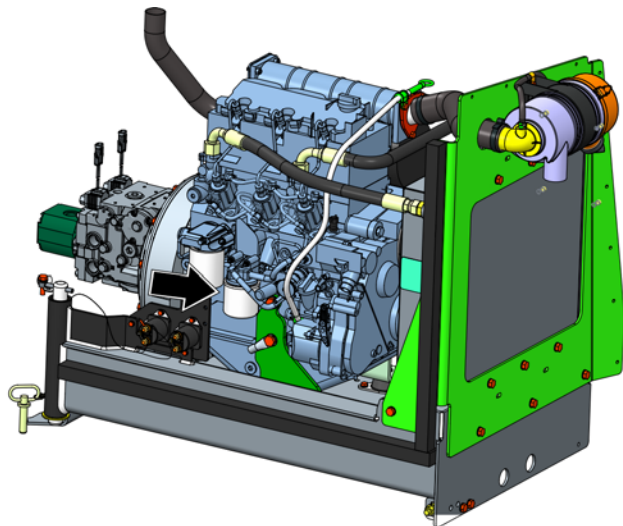

Lube Point(s) - Replaceable Element
Interval - Every year or 500 hours of operation

12. Fuel Pre-Filter - Deutz D2.9



Lube Point(s) - Replaceable Element
Interval - Drain water daily; Every year or 600 hours of operation

SECTION 7 - GENERAL SPECIFICATIONS & OPERATOR MAINTENANCE

13. Fuel Filter - Deutz D2.9



Lube Point(s) - Replaceable Element
Interval - Every year or 600 hours of operation

14. Fuel Filter (Gasoline) - GM

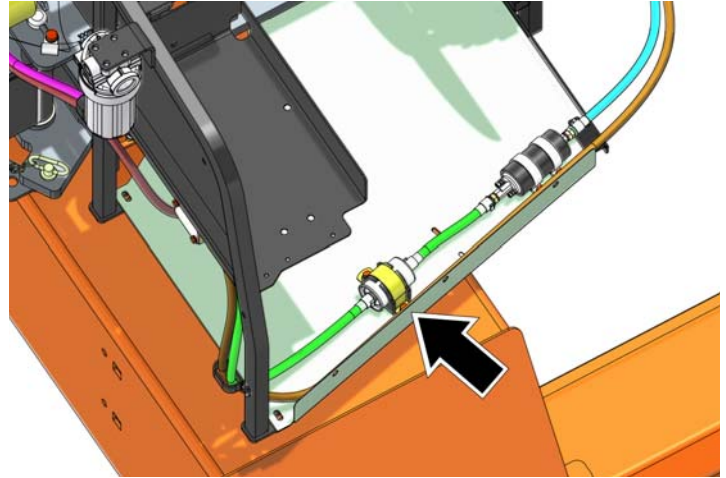

Lube Point(s) - Replaceable Element
Interval - Every 6 months or 300 hours of operation

SECTION 7 - GENERAL SPECIFICATIONS & OPERATOR MAINTENANCE

15. Fuel Filter (Propane) - GM Engine

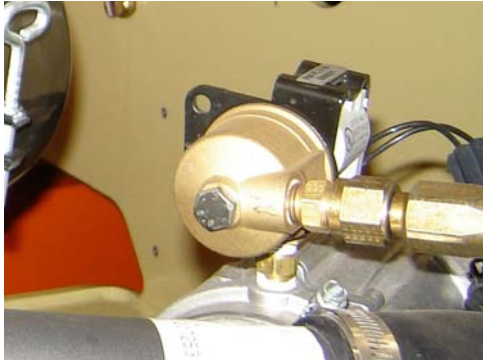

Interval - 3 Months or 150 hours of operation

Comments - Replace filter. Refer to Section 7.5, Propane Fuel Filter Replacement (GM Engine)

16. Charge Filter

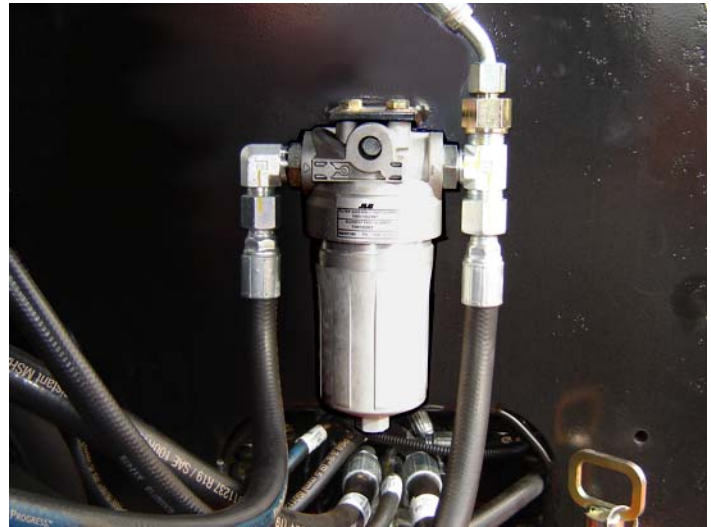

Interval - Change after first 50 hrs. and every 6 months or 300 hrs. thereafter.

Comments - Remove the engine tray retaining bolt and pull out engine tray to gain access.

SECTION 7 - GENERAL SPECIFICATIONS & OPERATOR MAINTENANCE

17. Air Filter



Lube Point(s) - Replaceable Element
Interval - Every 6 months or 300 hours of operation or as indicated by the condition indicator
Comments - Check Dust Valve daily

18. Engine Coolant



Lube Point(s) - Fill Cap
Capacity (Deutz 2.9L)- 2.9 gal. (11.3L)
Capacity (GM 3.0L)- 2.4 gal. (9.1L)
Capacity (Kubota) - 2.25 gal. (8.5 L)
Lube - Anti-Freeze
Interval - Check level daily; change every 1000 hours or two years, whichever comes first.

SECTION 7 - GENERAL SPECIFICATIONS & OPERATOR MAINTENANCE

19. Wheel Bearings

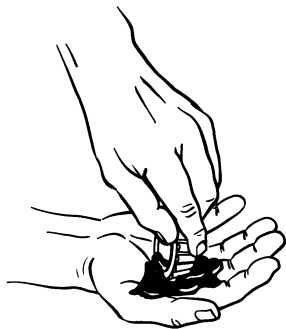

Lube Point(s) - Repack
Capacity - A/R
Lube - MPG
Interval - Every 2 years or 1200 hours of operation

20. Oil Change w/Filter - Kubota

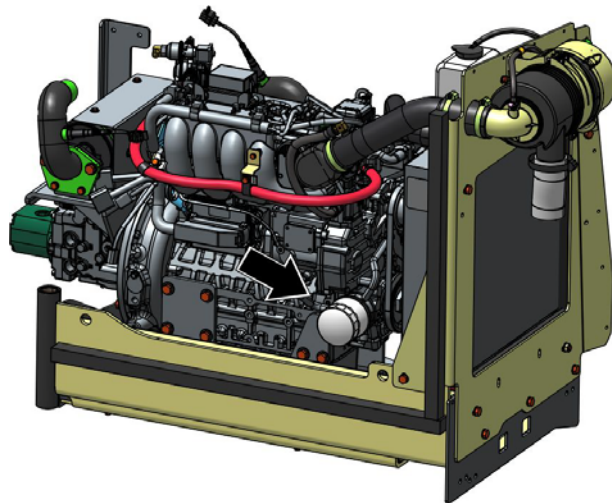

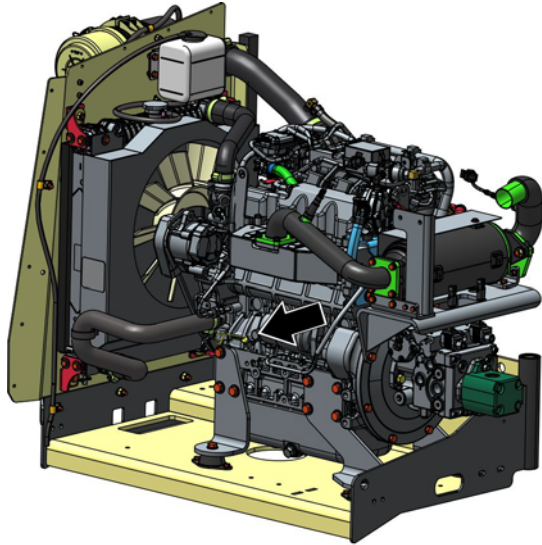

Lube Point(s) - Fill Cap/Spin-on Element
Capacity - 2.5 gal. (9.5 L) w/filter
Lube - EO
Interval - 3 Months or 150 hours of operation
Comments - Check level daily/Change in accordance with engine manual

21. Fuel Filter - Kubota

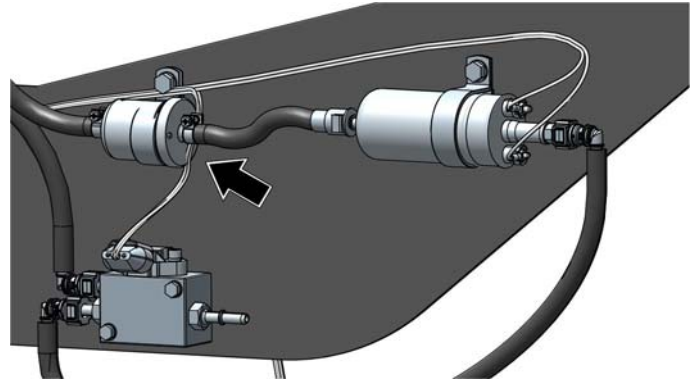

Lube Point(s) - Replaceable Component
Interval - Every year or 600 hours of operation

SECTION 7 - GENERAL SPECIFICATIONS & OPERATOR MAINTENANCE

22. Fuel Filter (Propane) - Kubota

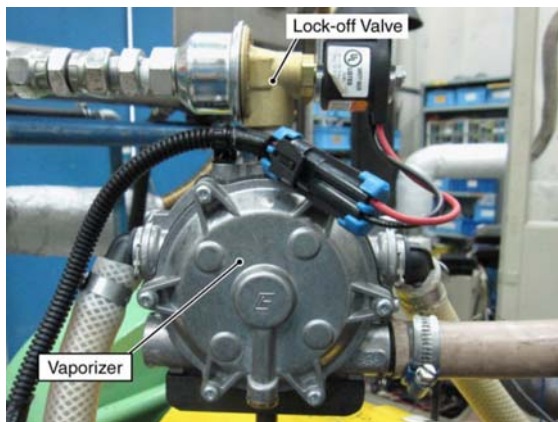

Interval - Every year or 1000 hours of operation
Comments - Replace filter. Refer to Section 7.6, Propane Fuel Filter Replacement (Kubota Engine)

7.4 TIRES & WHEELS

Tire Replacement

JLG recommends a replacement tire be the same size, ply and brand as originally installed on the machine. Please refer to the JLG Parts Manual for the part number of the approved tires for a particular machine model. If not using a JLG approved replacement tire, we recommend that replacement tires have the following characteristics:

- Equal or greater ply/load rating and size of original
- Tire tread contact width equal or greater than original
- Wheel diameter, width, and offset dimensions equal to the original
- Approved for the application by the tire manufacturer (including inflation pressure and maximum tire load)

Unless specifically approved by JLG Industries Inc. do not replace a foam filled or ballast filled tire assembly with a pneumatic tire. When selecting and installing a replacement tire, ensure that all tires are inflated to the pressure recommended by JLG. Due to size variations between tire brands, both tires on the same axle should be the same.

Wheel and Tire Replacement

The rims installed on each product model have been designed for stability requirements which consist of track width, tire pressure, and load capacity. Size changes such as rim width, center piece location, larger or smaller diameter, etc., without written factory recommendations, may result in an unsafe condition regarding stability.

Wheel Installation

It is extremely important to apply and maintain proper wheel mounting torque.

WARNING

WHEEL NUTS MUST BE INSTALLED AND MAINTAINED AT THE PROPER TORQUE TO PREVENT LOOSE WHEELS, BROKEN STUDS, AND POSSIBLE DANGEROUS SEPARATION OF WHEEL FROM THE AXLE. BE SURE TO USE ONLY THE NUTS MATCHED TO THE CONE ANGLE OF THE WHEEL.

Tighten the lug nuts to the proper torque to prevent wheels from coming loose. Use a torque wrench to tighten the fasteners. If you do not have a torque wrench, tighten the fasteners with a lug wrench, then immediately have a service garage or dealer tighten the lug nuts to the proper torque. Over-tightening will result in breaking the studs or permanently deforming the mounting stud holes in the wheels. The proper procedure for attaching wheels is as follows:

SECTION 7 - GENERAL SPECIFICATIONS & OPERATOR MAINTENANCE

1. Start all nuts by hand to prevent cross threading. DO NOT use a lubricant on threads or nuts.
2. Tighten nuts in the following sequence.

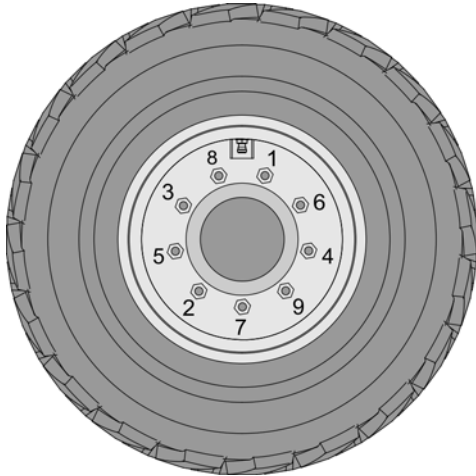

3. The tightening of the nuts should be done in stages. Following the recommended sequence, tighten nuts per wheel torque.
4. Wheel nuts should be torqued after first 50 hours of operation and after each wheel removal. Check and torque every 3 months or 150 hours of operation.

Table 7-17. Wheel Torque Chart

TORQUE SEQUENCE		
1st Stage	2nd Stage	3rd Stage
40 ft lbs (55 Nm)	95 ft lbs (130 Nm)	170 ft lbs (230 Nm)

7.5 PROPANE FUEL FILTER REPLACEMENT (GM ENGINE)

Removal

1. Relieve the propane fuel system pressure. Refer to Propane Fuel System Pressure Relief.
2. Disconnect the negative battery cable.
3. Slowly loosen the Filter housing and remove it.
4. Pull the filter housing from the Electric lock off assembly.
5. Remove the filter from the housing.
6. Locate Filter magnet and remove it.
7. Remove and discard the housing seal.
8. If equipped, remove and discard the retaining bolt seal.
9. Remove and discard mounting plate to lock off O-ring seal.

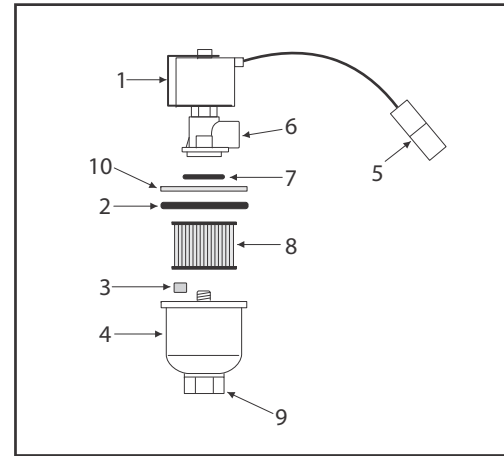

- | | |
|-------------------------------|----------------|
| 1. Electric Lock Off Solenoid | 6. Fuel Outlet |
| 2. Housing Seal | 7. O-ring |
| 3. Filter Magnet | 8. Filter |
| 4. Filter Housing | 9. Fuel Inlet |
| 5. Electrical Connector | 10. Ring |

Figure 7-13. GM Filter Lock Assembly

Installation

NOTICE

BE SURE TO REINSTALL THE FILTER MAGNET INTO THE HOUSING BEFORE INSTALLING NEW SEAL

1. Install the mounting plate to lock off O-ring seal.
2. If equipped, install the retaining bolt seal.
3. Install the housing seal.
4. Drop the magnet into the bottom of the filter housing.
5. Install the filter into the housing.
6. If equipped, install the retaining bolt into the filter housing.
7. Install the filter up to the bottom of the electric lock off.
8. Tighten the filter bowl retainer to 106 in-lb (12 Nm).
9. Open manual shut-off valve. Start the vehicle and leak check the propane fuel system at each serviced fitting.

7.6 PROPANE FUEL FILTER REPLACEMENT (KUBOTA ENGINE)

Removal

1. Relieve the propane fuel system pressure. Refer to Propane Fuel System Pressure Relief.
2. Disconnect the negative battery cable.
3. Slowly loosen the bowl retaining nut and remove the nut and filter housing from the Electric lock off assembly.
4. Remove the filter from the housing.
5. Remove and discard the housing seal.
6. Remove and discard the retaining nut seal.

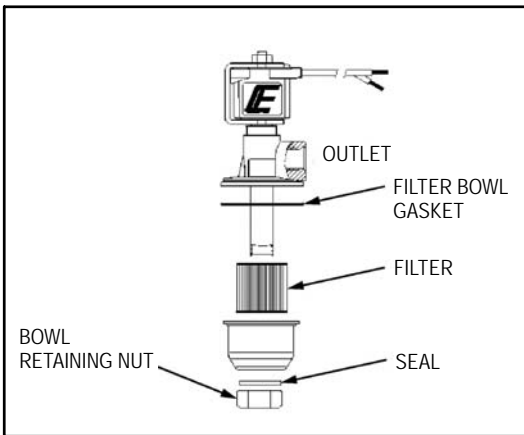

Figure 7-14. Kubota Filter Lock Assembly

Installation

1. If equipped, install the filter bowl gasket.
2. Install the filter into the housing.
3. Install the filter bowl up to the bottom of the electric lock off.
4. Tighten the filter bowl retainer nut.
5. Open manual shut-off valve. Start the vehicle and leak check the propane fuel system at each serviced fitting.

7.7 PROPANE FUEL SYSTEM PRESSURE RELIEF

CAUTION

THE PROPANE FUEL SYSTEM OPERATES AT PRESSURES UP TO 312 PSI (21.5 BAR). TO MINIMIZE THE RISK OF FIRE AND PERSONAL INJURY, RELIEVE THE PROPANE FUEL SYSTEM PRESSURE (WHERE APPLICABLE) BEFORE SERVICING THE PROPANE FUEL SYSTEM COMPONENTS.

To relieve propane fuel system pressure:

1. Close the manual shut-off valve on the propane fuel tank.
2. Start and run the vehicle until the engine stalls.
3. Turn the ignition switch OFF.

CAUTION

RESIDUAL VAPOR PRESSURE WILL BE PRESENT IN THE FUEL SYSTEM. ENSURE THE WORK AREA IS WELL VENTILATED BEFORE DISCONNECTING ANY FUEL LINE.

7.8 SUPPLEMENTAL INFORMATION

The following information is provided in accordance with the requirements of the European Machinery Directive 2006/42/EC and is only applicable to CE machines.

For electric powered machines, the equivalent continuous A-Weighted sound pressure level at the work platform is less than 70dB(A)

For combustion engine powered machines, guaranteed Sound Power Level (LWA) per European Directive 2000/14/EC (Noise Emission in the Environment by Equipment for Use Outdoors) based on test methods in accordance with Annex III, Part B, Method 1 and 0 of the directive, is 102 dB.

The vibration total value to which the hand-arm system is subjected does not exceed 2,5 m/s². The highest root mean square value of weighted acceleration to which the whole body is subjected does not exceed 0,5 m/s².



An Oshkosh Corporation Company

TRANSFER OF OWNERSHIP

To Product Owner:

If you now own but ARE NOT the original purchaser of the product covered by this manual, we would like to know who you are. For the purpose of receiving safety-related bulletins, it is very important to keep JLG Industries, Inc. updated with the current ownership of all JLG products. JLG maintains owner information for each JLG product and uses this information in cases where owner notification is necessary.

Please use this form to provide JLG with updated information with regard to the current ownership of JLG products. Please return completed form to the JLG Product Safety & Reliability Department via facsimile or mail to address as specified below.

Thank You,
Product Safety & Reliability Department
JLG Industries, Inc.
13224 Fountainhead Plaza
Hagerstown, MD 21742
USA
Telephone: +1-717-485-6591
Fax: +1-301-745-3713

NOTE: Leased or rented units should not be included on this form.

Mfg. Model: _____

Serial Number: _____

Previous Owner: _____

Address: _____

Country: _____ Telephone: (____) _____

Date of Transfer: _____

Current Owner: _____

Address: _____

Country: _____ Telephone: (____) _____

Who in your organization should we notify?

Name: _____

Title: _____



3121658



An Oshkosh Corporation Company

Corporate Office

JLG Industries, Inc.

1 JLG Drive

McConnellsburg, PA 17233-9533 USA

☎ (717) 485-5161 (Corporate)

☎ (877) 554-5438 (Customer Support)

☎ (717) 485-6417

Visit our website for JLG Worldwide Locations.

www.jlg.com